

EXPERIMENT 05
EXPERIMENT 07
EXPERIMENT 08

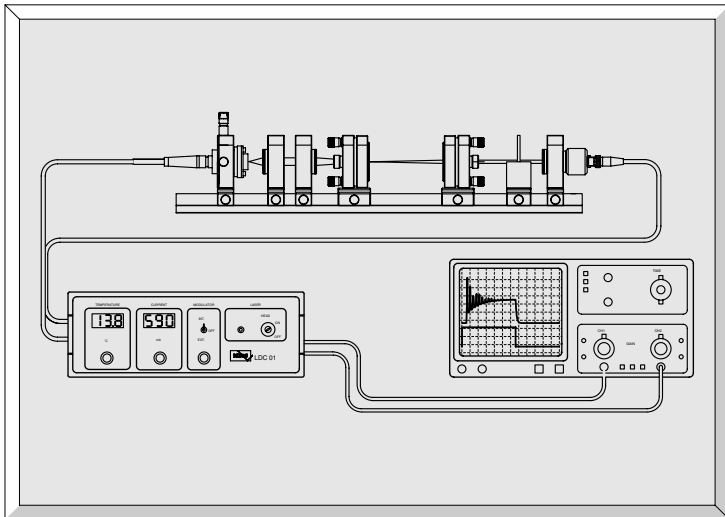

Diodelaser Pumped
Nd : YAG Laser

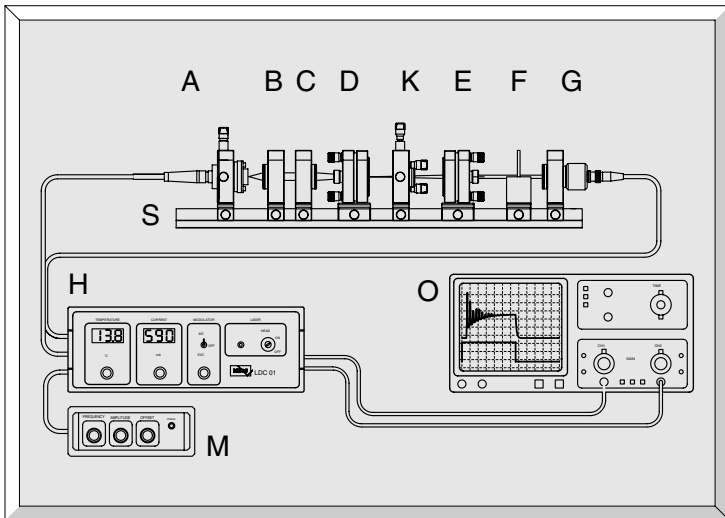
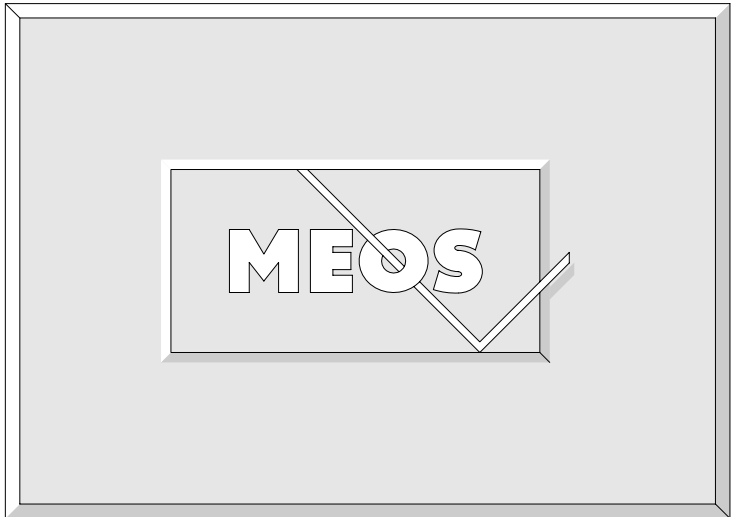

Didactic Counsellor
Prof. Dr.-Ing. Dickmann

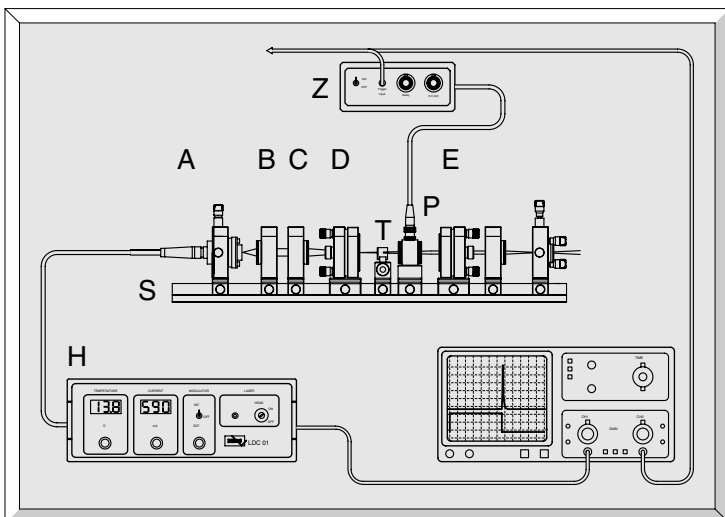

Fachhochschule
Münster

Fachbereich
Physikal. Technik

1	THE ND YAG-LASER	4
1.1	Optical pumping	4
1.2	Four-level system of the Nd-YAG laser.	6
1.3	Rate equation model for four levels	6
1.1.1	Solution of the rate equations	7
1.1.2	Steady-state solution	7
1.1.3	Time-varying solution of the rate equations	8
1.1.4	Spiking	8
1.1.5	Q-switching	9
2	LASER RESONATOR	10
2.1	Types of resonators	10
2.2	Stability criterion	11
1.3	Resonator modes	11
1.3.1	Longitudinal modes	11
1.1.2	Gain profile	12
1.1.3	Transverse modes	12
3	THE PUMP-LIGHT SOURCE	13
3.1	Diode Laser	13
4	SECOND HARMONIC GENERATION	15
4.1	Introduction	15
4.2	Interaction of light and matter	16
4.3	Non-linear Optics	16
4.4	Frequency doubling	17
4.5	Phase matching	17
5	Q-SWITCH	20
5.1.1	Mechanical Q-switch	20
5.1.2	Optical Q-switcher	20
5.1.3	Passive Q-switch	21
5.1.4	Pockel's cell	22
6	SET-UP AND PERFORMANCE OF THE ND:YAG-LASER	25
6.1	The Modules	25
6.2	Experimental set-up for characterising the laserdiode	27
6.2.1	Absorption spectrum	28
6.2.2	Wavelength and temperature dependence	28

6.2.3	Laser diode output power	29
6.3	The $4F_{3/2}$ life-time measurement	30
6.4	The Nd-YAG laser set-up	31
6.5	Laser operation	31
6.5.1	Measurement of threshold and output power of the Nd-YAG laser	31
6.5.2	Output power at various pump wavelengths	32
6.5.3	Display of transverse modes	32
6.5.4	Demonstration of Spiking	32
6.5.5	Operation of the 1.3 μm Line	33
6.5.6	Mode Aperture and TEM ₀₀ Operation	33
7	SECOND HARMONIC GENERATION	34
7.1	Modules and Set-Up	34
7.2	Dynamic measurements	35
8	PASSIVE Q-SWITCH	36
8.1	Modules and Set-Up	36
9	ACTIVE Q-SWITCH	37
9.1	Modules and Set-Up	37
9.2	Intra-cavity second harmonic generation with Q-switched laser	39
9.3	Extra-cavity second harmonic generation with Q-switched laser	40
10	LASER SAFETY	41
11	THE LASERDIODE CONTROLLER LDC01	42

1 The Nd YAG-Laser

1.1 Optical pumping

Optical pumping is a process in which light is radiated into a specimen under investigation and the effect of the light on the specimen is examined. It was in this way that the strange physical phenomenon was observed of atoms only being able to accept or release energy in well defined quantities. This observation led to the conclusion that atoms only have discrete energy states or energy levels.

When light is absorbed or emitted, a transfer takes place between the energy levels (Fig. 1.1). A transition from the level with the energy E_1 to a level with the energy E_2 can occur if an incoming photon is absorbed with the energy $E_{ph} = E_2 - E_1$. In the reverse case, a photon with the energy $E_{ph} = E_2 - E_1$ is emitted if a transition of the atom takes place from a state with energy E_2 to one with energy E_1 . The two processes of absorption and emission differ in that an external field with the energy E_{ph} must be present for absorption, whereas no field is present for emission. This emission occurs spontaneously from the system itself without external fields. It can be compared to the radioactive decay of an excited nucleus. The analogous inverse process to absorption, i.e. emission under the application of external fields is termed induced emission.

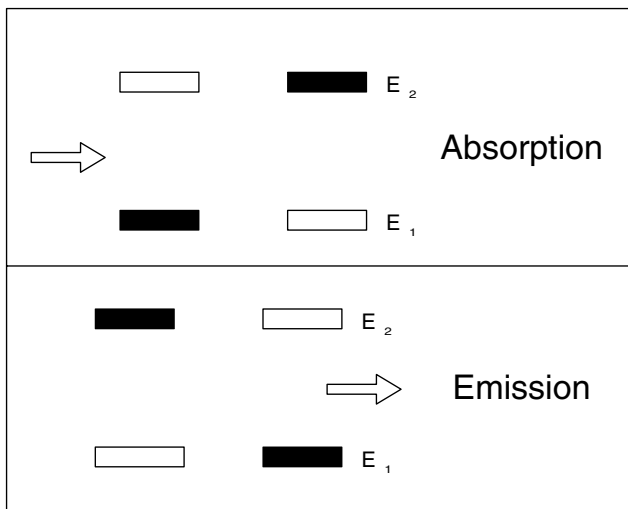

Fig. 1.1: Absorption and emission

For each of the processes the number of atoms can be stated which absorb or emit a photon per unit of time and per unit of volume.

$$\frac{dn_1}{dt} = -B_{12} \cdot n_1 \cdot u_{ph} \quad \text{Absorption}$$

$$\frac{dn_2}{dt} = -B_{21} \cdot n_2 \cdot u_{ph} \quad \text{Induced emission}$$

$$\frac{dn_2}{dt} = -A_{21} \cdot n_2 \quad \text{Spontaneous emission}$$

B_{12} denotes the Einstein coefficient of absorp-

tion,

B_{21} the Einstein coefficient of induced emission and

A_{21} the Einstein coefficient of spontaneous emission,

n_1 and n_2 are the densities of the atoms in the states 1 and 2 respectively,

u_{ph} is the energy density of the external field.

By integration of the equation for spontaneous emission, information is obtained on the variation of this type of emission with respect to time:

$$n_2(t) = n_2(t_0) \cdot e^{-A_{21} \cdot t}$$

A decay probability and a mean life-time can be given completely analogous to radioactive decay. The Einstein coefficient A_{21} represents this probability and

$$\tau = \frac{1}{A_{21}} \quad \text{the mean life-time.}$$

This states the time which passes before the number of excited atoms has reduced to $1/e$ or before $n_2(t)$ has reached the value

$$n_2(t) = n_2(t_0) \cdot \frac{1}{e}$$

For normal optical transitions, this value is between 10^{-8} and 10^{-9} sec. This life-time which is determined by the spontaneous transitions alone is relevant for the natural half width of a spectral line. According to the Heisenberg uncertainty principle, there is a relationship between the width and the life-time:

$$2\pi \cdot d\nu = \frac{1}{\tau} = A_{21}$$

where $d\nu$ is the half-width of the spectral line.

According to the above requirements transitions will only take place if the energy of the absorbed or emitted photon is sharply defined, i.e.

$$E_{ph} = E_2 - E_1$$

In actual fact nature is not that critical and it is seen that photons with a slightly different energy also take part in these processes. The reason for this is that the energy levels are broadened due to various mechanisms.

Depending on how mobile the atoms are due to their temperature and how they are affected by interactions with their environment, there is a broadening dE which means that photons within this region are accepted. The width of the transition is given by the half width dE for the relevant transition (Fig. 1.2). The same theory is valid for emission.

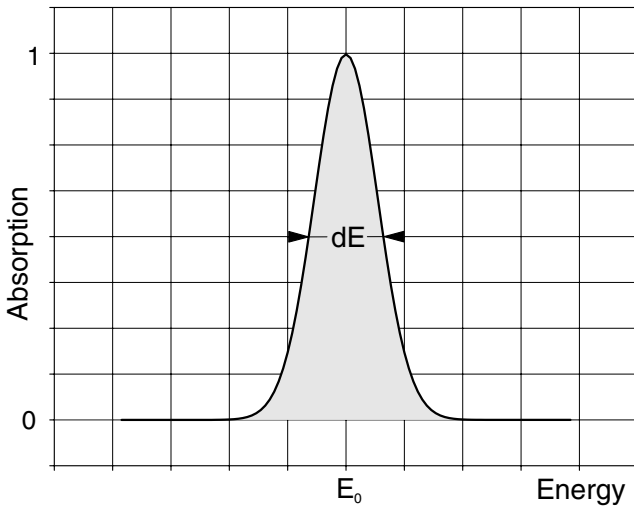

Fig. 1.2: Broadened absorption transition.

E_0 is the energy at which the absorption is the highest. It corresponds to the value $E_2 - E_1$. For the sake of completeness it should be mentioned that there are also situations in which this value can be displaced. The shape of the absorption curve corresponds to a Gaussian distribution. By definition dE is the width of the curve at which the absorption has fallen to one half of the maximum value. This is known as the full width at half maximum (*FWHM*). If there are other transitions within the vicinity of this transition, they may overlap, producing a substantially wider absorption curve (Fig. 1.3). This is particularly important in the case of the absorption of laser diode radiation in Nd-YAG which is discussed later.

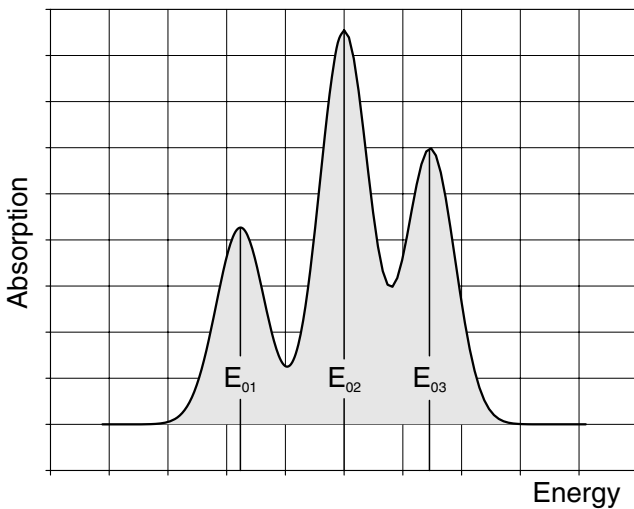

Fig. 1.3: Absorption for three neighbouring transitions with different absorption strengths

In principle an atom may have any number of energy levels, but they must be discrete. The transitions between the individual levels take place according to defined selection criteria. When the atom is excited with a defined energy, an emission spectrum is observed with characteristic energies and this spectrum gives precise information about the energy levels involved. Excitation by optical pumping has therefore developed as a very important method used in spectroscopy. It is also an indispensable technique for the excitation of a number of different types of lasers. Optical

pumping in conjunction with Nd-YAG lasers is of particular interest, because these have become widely accepted for industrial use, along with the CO₂ laser. The laser-active material which, in the case of the Nd-YAG laser, is excited by optical pumping, consists of Neodymium atoms that are accommodated in a transparent host crystal (YAG = Yttrium Aluminium Garnet). Whereas up to a few years ago Nd-YAG lasers were almost excited using discharge lamps, optical pumping with laser diodes is becoming more significant. This is because laser diodes are available economically and they emit narrow band light at high optical powers, which matches the energy levels of the Nd-YAG crystal (Fig. 1.4). The advantage over the discharge lamp is that the emission of laser diodes is nearly completely absorbed by the Nd-YAG, whereas the very wide spectral emission of discharge lamps is absorbed to only a small extent. The efficiency of optical pumping with discharge lamps is about 3%, but figures of up to 50% can be achieved using laser diodes!

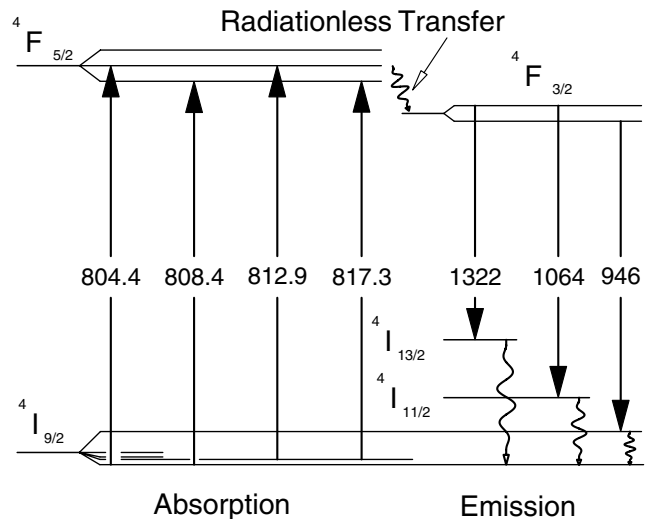

Fig. 1.4: Relevant energy levels of Nd-YAG for optical pumping with laser diodes having wavelengths around 805 nm

Some energy levels of the Nd atom are illustrated in Fig. 1.4. Here, only those are shown which are significant for optical pumping with laser diodes and which are important for the laser process. The levels are labelled with their spectroscopic notations. Since the Nd atoms are situated within the YAG host crystal, the otherwise degenerated energy levels of the isolated Nd atom split into a number of states. This gives rise to the ground state $4I_{9/2}$ from 5 substates and the state $4F_{5/2}$, which can be pumped from 5 substates. Since the wavelength of the pump-light source (diode laser) can vary within low limits, a total of three to four transitions can be pumped with high efficiency. The Nd atoms of the $4F_{5/2}$ state pass very quickly into the laser output level $4F_{3/2}$. The laser transition which is technically most interesting takes place between the $4F_{3/2}$ state as starting level and terminates in the $4I_{11/2}$ state with an emitted wavelength of 1064 nm. From here the Nd atoms relax again into the ground state $4I_{9/2}$ until the pumping process starts from the beginning again. The Neodymium therefore has an ideal four level system.

1.2 Four-level system of the Nd-YAG laser.

The principle is shown in Fig. 1.5. Under the radiation of a light field (optical pumping), transitions from ground state 1 to the upper level 4 occur. The reverse processes from state 4 to state 1 are prevented by very fast transitions from state 4 to state 3 without radiation. The laser transition takes place from level 3 into level 2 which is thermally not populated. From here the Nd atoms relax again back to ground state 1.

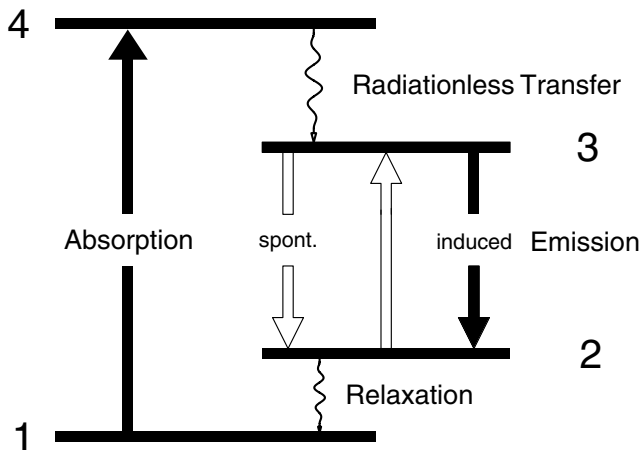

Fig. 1.5: Principle of the four-level laser

- W_{14} probability of absorbing a pump photon.
- S_{43} probability of relaxation from state 4 to 3 .
- S_{32} probability of spontaneous emission of a photon.
- W_{32} probability of induced emission of a photon.
- W_{23} probability of induced absorption of a photon.
- S_{21} probability of relaxation from state 2 to state 1.

The irradiation by light, which leads to the population of an otherwise empty state, is termed optical pumping. The emptying of a level occurs either with the emission of photons or without radiation. Transitions without radiation take place due to mechanical interactions such as collisions or vibrations and they are also designated as relaxation. The number of transitions without radiation per second is termed the relaxation rate. Transitions in which photons are emitted occur spontaneously or are induced. Spontaneous transitions also occur without pumping processes. However, induced emissions only occur if a pumping process takes place. Rates are also stated here, one rate for spontaneous emission and another one for induced emission. Each state which can interact with one or more other states is labelled with this type of rates. However, in Fig. 1.5 showing the principle, only the transition probabilities that are significant for the pump and laser processes are indicated. All the designated levels are populated to some extent due to pumping. The extent to which each state is populated is given by the number N_i of Nd atoms which are in the relevant state i of excitation:

State 1	N_1
State 2	N_2
State 3	N_3

State 4 N_4

Under the realistic assumption made in this example that the Nd atoms only pass through the labelled excitation steps, the sum of the population densities gives the Nd atoms which are available. The desired laser oscillation will, however, only be achieved if an adequate population inversion can be established between states 3 and 2. The conditions under which laser emission occurs, together with how the laser behaves, can be predicted by a model of the so called rate equation model. Initially, the main interest will be focused on continuous laser operation.

1.3 Rate equation model for four levels

The model describes the situation in a simple but exact manner. Each of the levels involved is regarded as a reservoir to which or from which "particles" flow. The particles used in this picture represent the Nd YAG atoms related to their corresponding state. Particle streams flowing to the level are given a positive sign, those flowing away are given a negative sign. This is carried out for each of the involved states.

The number of excited atoms per unit of time in state 3 is:

$$\left. \frac{dN_3}{dt} \right|_p = \eta \cdot W_{14} \cdot N_1 = W_p \cdot N_1 \quad \text{pump rate}$$

where η is the pumping efficiency. The transition from state 4 occurs so fast that the level 3 is pumped immediately and the population N_4 density of state 4 is therefore $N_4 \sim 0$.

Spontaneous process

Another process affecting state 3 is spontaneous emission:

$$\left. \frac{dN_3}{dt} \right|_s = -\Gamma \cdot N_3 \quad \text{spontaneous rate,}$$

where $\Gamma = 1/\tau_s$, τ_s is the mean life-time of a photon before it is spontaneously emitted.

Induced processes

Finally, the induced processes occurring between states 3 and 2 under the influence of the laser field must also be considered. The relevant rates are proportional to the difference in the population numbers N_2 and N_3 and to the photon density p of the laser field. The effective cross-section σ for the emission or absorption of a photon arises as a constant of proportionality:

$$\left. \frac{dN_3}{dt} \right|_i = \sigma \cdot c \cdot p \cdot (N_2 - N_3) \quad \text{induced rate.}$$

Therefore the variation in the population density of level 3 with respect to time can be written as the sum of the separate rates:

$$\frac{dN_3}{dt} = \sigma \cdot c \cdot p \cdot (N_2 - N_3) - \Gamma \cdot N_3 + W_p \cdot N_1$$

Furthermore, the assumption is made that the transition from state 2 to state 1 is also so fast that only very few of the particles accumulate in state N_2 that means $N_2 = 0$ and the total number N_0 of Nd atoms is therefore:

$$N_0 = N_1 + N_3$$

Since N_0 is constant, also $dN_0/dt = 0$ and dN_1/dt becomes $-dN_3/dt$. Therefore the variation of the population density N_1 with respect to time is:

$$\frac{dN_1}{dt} = -\sigma \cdot c \cdot p \cdot (N_2 - N_3) + \Gamma \cdot N_3 - W_p \cdot N_1$$

It is important for the later laser process to know how the photon density on the laser transition 3 to 2 varies with respect to time. With each „induced“ absorption process a photon is annihilated and a photon is created with each induced emission process.

$$\left. \frac{dp}{dt} \right|_i = -\sigma \cdot c \cdot p \cdot (N_2 - N_3) \quad \text{induced}$$

Once created, the photon density does not remain in a resonator, instead it reduces with the time constant τ_{ph} , because photons are leaving at the mirrors of the resonators or are lost in other ways.

$$\left. \frac{dp}{dt} \right|_l = -\frac{p}{\tau_{ph}} \quad \text{losses}$$

The complete variation of the photon density with respect to time is:

$$\frac{dp}{dt} = \sigma \cdot c \cdot p \cdot (N_3 - N_2) - \frac{p}{\tau_{ph}}$$

For simplification the population inversion $N_3 - N_2$ is designated as n . The variation of the population inversion with respect to time is obtained by the following relations:

$$\frac{dn}{dt} = -\sigma \cdot c \cdot p - \Gamma \cdot n + W_p \cdot (N_0 - n) \quad (1.1)$$

and for the photon density:

$$\frac{dp}{dt} = p \cdot \left(\sigma \cdot c \cdot n - \frac{1}{\tau_{ph}} \right). \quad (1.2)$$

1.3.1 Solution of the rate equations

The differential equations (1.1) and (1.2) form a pair of coupled conditional equations for the two unknown functions $n(t)$ and $p(t)$. The equations are non-linear because

they both contain the term pn . Analytical solutions are not known and one has to rely on computerised solutions.

1.3.2 Steady-state solution

When the system is in the state of equilibrium, i.e. for steady-state laser operation, the values for dn/dt and dp/dt are equal to zero. In this case an expression for the population inversion is obtained immediately:

$$n = \frac{N \cdot W_p}{\sigma \cdot c \cdot p + W_p + \Gamma}$$

When the laser is operated below or just at the threshold, no photon field is formed ($p=0$). In this case $Wp \ll \Gamma$ and the threshold inversion is given by:

$$n(p=0) = n_0 = N \cdot \frac{W_p}{\Gamma}$$

This equation states that in a four-level laser an inversion immediately is produced when it is pumped. This is a particular advantage as opposed to other laser systems. Unfortunately, neither the photon density nor the pumping rate are directly accessible by measurement.

However, the photon density is coupled to an easily measured quantity, i.e. the power applied in the pumping process. If the relationships between the photon density p and the corresponding intensity, as well as the resonator output and loss characteristics are considered, the output power P_a of a four-level laser can be obtained as:

$$P_a = \eta \cdot \frac{E_{32}}{E_{41}} \cdot (P_p - P_{th}) \cdot \frac{T}{T + L} \quad (1.3)$$

In this equation E_{32} signifies the energy difference between states 3 and 2 (laser wavelength). E_{41} is the energy difference between states 4 and 1 (pump wavelength), T is the transmission of the output coupling mirror, L is the loss in the resonator due to dispersion, absorption or reflection. P_p is the pump power and P_{th} is the threshold pump power.

Above the threshold pump power P_{th} the output power of the laser increases linearly with the pump power.

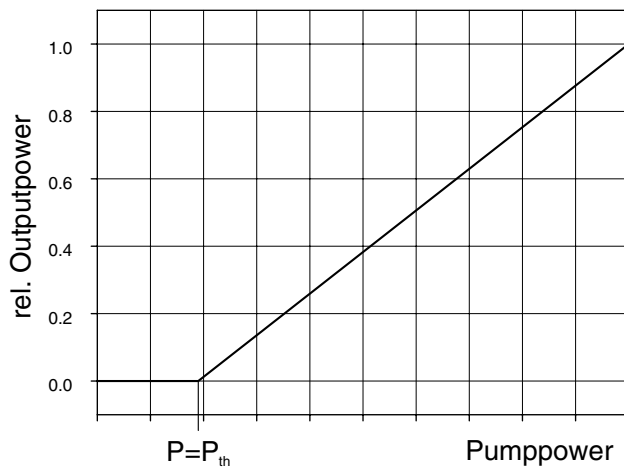

Fig. 1.6: Laser output power as a function of the pump power

The slope α_s of the straight line (Fig. 1.6) is one of the most important parameters of a laser and is termed the slope efficiency.

$$\alpha_s = \eta \cdot \frac{E_{32}}{E_{41}} \cdot \frac{T}{T+L} \quad (1.4)$$

The quantity E_{32}/E_{42} is also known as the quantum efficiency. It gives the energy ratio of a laser photon to the pump photon. For the Nd-YAG laser pumped by a diode laser this is, for example, $810 \text{ nm} / 1064 \text{ nm} = 0,76$. The value η is the quantum yield, but unfortunately sometimes both quantities are commonly named as the quantum efficiency. For the laser designer it is important to obtain the highest possible output at the highest possible efficiency. Another important feature is that the transmission T for the resonator output mirror must be selected as large as possible according to equation (1.4). However, this has the consequence that the threshold pump power P_{th} increases and the output power decreases according to equation (1.3). A compromise between both equations must therefore be found.

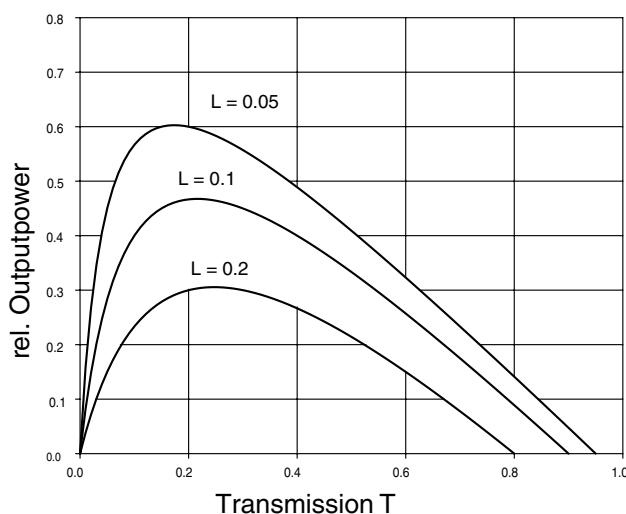

Fig. 1.7: Laser output power in dependence of the transmission T of the output mirror and the losses L .

In practice the losses L depend on various parameters of the resonator including the quality of the laser rod, the ab-

sorption losses of the laser mirror etc., so that a mathematical formula covering all effects would be too complicated. It has proven useful to measure the curve of Fig. 1.7 directly at the laser to find the degree of output coupling. A series of output mirrors with various transmission values is used for this purpose.

1.3.3 Time-varying solution of the rate equations

The previous solutions described the situation where the laser operates in a steady state. However, for practical operation of the laser, conditions in disturbed equilibrium must also be considered. These kinds of disturbances occur when the intensity of the pump-light source change or the laser resonator is slightly disturbed mechanically. Large deviations from the steady state are particularly important when they cause problems (e.g. spiking and hot spots), but also when they lead to useful operating modes (Q switching). Small deviations of the steady state with $\delta n \ll n$ or $\delta p \ll p$ lead to damped harmonic oscillations of n and p . Larger deviations produce undamped non-harmonic oscillations. In this case, power peaks (spiking) of such a intensity may occur that the laser mirrors or the Nd-YAG materials can be destroyed. However, if disturbances are carried out in a controlled manner, these types of power peaks, which extend up into the gigawatt region (!), can be used to advantage. Computerised solutions must be used in calculating the solutions to the rate equations for these cases. In the following, these cases are therefore only qualitatively described.

1.3.4 Spiking

A large deviation from the steady state undoubtedly occurs when the laser is switched on or when the pump-light source is switched on. Until the threshold pump power P_{th} is reached, there are practically no photons present in the resonator.

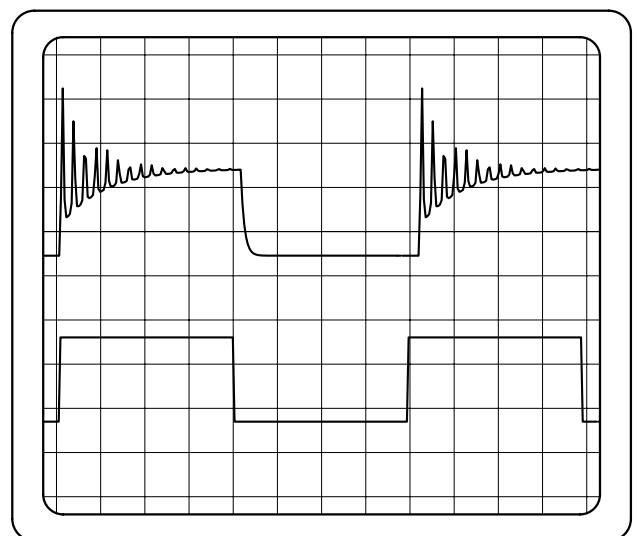

Fig. 1.8: Spiking of the Nd-YAG laser

When the population inversion reaches the threshold, a photon field is formed. However, due to the resonator propagation time, it takes a while until the photon density reaches the steady state value. During this period the in-

version, which rises linearly with time, increases above the value of the threshold inversion. This in turn means a more rapid increase in the photon density. This rise is so rapid that the inversion falls to a value slightly below the threshold and the laser oscillation stops (Fig. 1.8). The process starts again, but this time the laser is only slightly below the threshold and the expected inversion overshoot is not so large as before. In this manner the system approaches the steady state. The first power spike (initial spike) can reach a peak power of a factor 100 to 1000 higher than the steady state power value. Spiking therefore can cause serious problems and it can lead to the destruction of the optical surfaces so that the laser might destroy itself during switch-on. This behaviour which will be observed in the latter experiments indicates, that the Nd YAG crystal can store energy.

1.3.5 Q-switching

The quality of a resonator is the quotient of the resonance frequency and the half width of the resonance curve. The definition is the same as for oscillator circuits known from electronics. A low Q figure for a resonator signifies high losses and vice versa. In a laser resonator with low Q, a high inversion can be produced without laser oscillation, because the threshold is high. If the resonator Q is then suddenly switched to a higher value, a high photon density is formed and a large part of the inversion stored in the laser-active material transfers into the photon field. This is a similar process as discussed with the occurrence of spiking. In contrast to spiking, here the laser threshold is controlled by the insertion and removal of resonator losses. The losses can be switched with an electro-optical switch or by a saturable absorber, which transmission depends on the irradiated intensity. In this experimental set-up a Lithium Fluoride crystal with colour centres can be used as saturable absorber. The energy level from which the laser emission of 1064 nm starts is the $^4F_{3/2}$ state (Fig. 1.4) which has a mean lifetime of app. 250 μ sec. This means that it takes 250 μ sec before the intensity of the spontaneous emission decreases to 1/e of its starting value, when the pumping field is switched off suddenly. This mean lifetime will be measured in a later experiment. For a laser system, this behaviour can be exploited for the generation of short pulses with high peak powers. Although the time dependent solution of the rate equations can not be derived by analytical expressions one can obtain some simple derivations under the following assumptions. Because of the very fast increase of the photon density the terms in Eq. (1.1) of the pumping rate and the rate of spontaneous emission can be neglected. The development in time of the population density (Eq. (1.1)) simplifies with

$$n_{th} = \frac{1}{\sigma \cdot c \cdot \tau_{ph}}$$

in this case to:

$$\frac{dn}{dt} = -\frac{n}{n_{th}} \cdot \frac{p}{\tau_{ph}} \quad (1.5)$$

and the photon density to:

$$\frac{dp}{dt} = \left(\frac{n}{n_{th}} - 1\right) \cdot \frac{p}{\tau_{ph}} \quad (1.6)$$

The above equations can be solved for the build up of the giant pulse when the population density n is nearly constant and corresponds appear. to the starting population n_i . Then Eq. (1.6) becomes:

$$\frac{dp}{p} = \frac{1}{\tau_{ph}} \cdot \left(\frac{n_i}{n_{th}} - 1\right) \cdot dt$$

with the solution for the photon density:

$$p(t) = e^{\left(\frac{n_i}{n_{th}} - 1\right) \cdot \frac{t}{\tau_{ph}}}$$

In accordance to the above solution the density of the photons rises exponential with a time constant τ , which is due $n_i/n_{th} \gg 1$ considerably lower than the life time τ_{ph} of the photons inside the resonator. An additional remarkable aspect in the development in time of the photon density is the point where the inversion $n(t)$ is decreased to n_{th} . At this moment dp/dt becomes 0 and therefore $p = \text{const.} = p_{\text{max}}$. Eq. (1.6) can now be written as:

$$\frac{dn}{dt} = -\frac{p_{\text{max}}}{\tau_{ph}}$$

The negative sign indicates that the inversion is decreasing further. No additional laser photons will be produced. The photon density reaches its maximum and decays now with the time constant

$$\tau_{ph} = \frac{L}{c \cdot (1 - R)}$$

related to the lifetime of the photons inside the resonator.

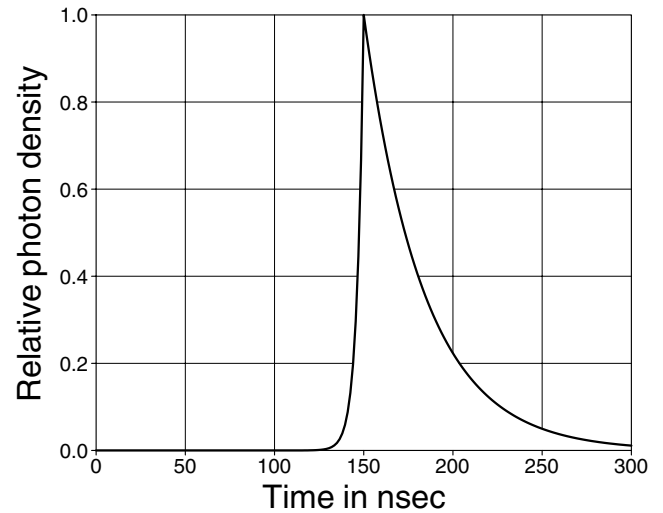

Fig. 1.9 : Calculated photon density for $n_i / n_{th} = 10$, a resonator length L of 100 mm and resonator losses of 1%. The rising part of the curve corresponds to the surplus inversion and the falling one to the photon life time inside the resonator

The peak value of the photon density is given by:

$$p_{\text{max}} = n_{th} \cdot \ln\left(\frac{n_{th}}{n_i}\right) - (n_{th} - n_i)$$

and the peak value of the intensity I_{max} by:

$$I_{\text{max}} = \frac{1 - R}{2} \cdot h \cdot \nu \cdot c \cdot p_{\text{max}}$$

The cross section of the stimulated emission σ for the transition 3-2 (Fig. 1.5) amounts $\sigma = 8.8 \cdot 10^{-19} \text{ cm}^{-2}$ and the photon energy $h\nu_{1064 \text{ nm}} = 2 \cdot 10^{-19} \text{ Joule}$.

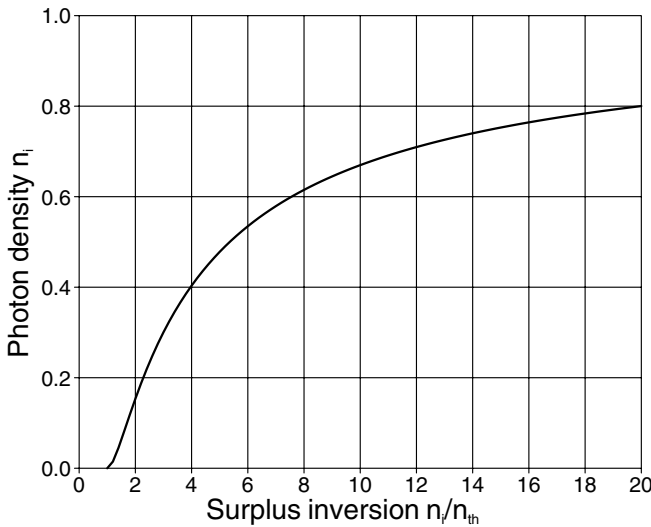

Fig. 1.10: Attainable peak value of the photon density relative to the initial inversion n_i versus the surplus inversion n_i / n_{th}

At this point of the discussion it becomes clear why lasers, who's starting energy level for the laser process has a low lifetime, do not exhibit a considerable increase of the output power under Q-switch operation. These lasers can only achieve a small value of a surplus inversion n_i / n_{th} .

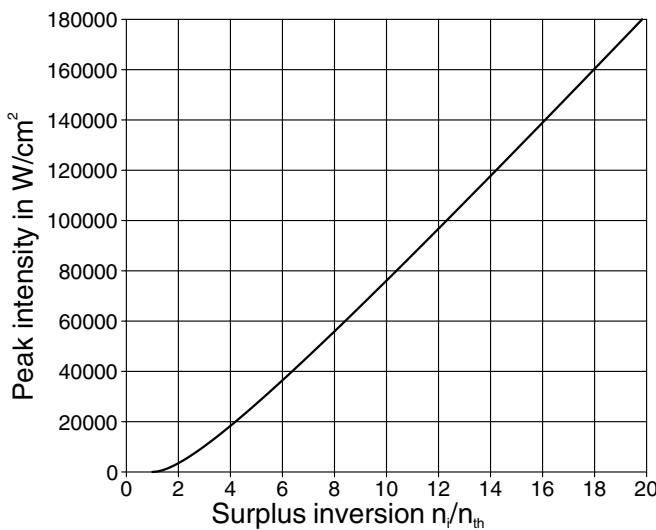

Fig. 1.11: Attainable peak intensities of the cw Nd YAG-Laser at T=1% in Q-switch mode

In the case of the CO_2 laser one can obtain a slight increase of the output power termed as super pulse instead of giant pulse for the YAG laser. For the He Ne Laser with a lifetime of the starting level of some nano seconds no increase of the laser power under Q-switch operation will be obtained. In the case of the Nd YAG laser with its lifetime of approx. 250 μsec of the starting level the duration of the giant pulse amounts 50 nsec, so that peak powers can be achieved which are considerably higher than the pump power itself. There are some techniques to realise the giant pulse operation of a laser. But they all work with

the same fundamental operation: the laser oscillation is prevented until a sufficient surplus inversion is attained. Of course it is also important that the releasing of the oscillation takes place sufficient quickly. In the ideal case $n_{th} = \infty$ for the blocked resonator and $n_{th} = \min$ for the released resonator. If for instance the threshold is varying slowly in time also n_i / n_{th} is reducing as well as the attainable peak power. The switching of the Q of the resonator can be achieved with pure mechanical, electro-optic modulator, acousto-optic modulator or by means of a saturable absorber. These different types of Q-switcher are described in the following chapters.

2 Laser Resonator

2.1 Types of resonators

The most simple optical resonator, the Fabry-Perot resonator, consists of a pair of plane or spherical mirrors located opposite one another. They are centred to a common optical axis and are aligned perpendicular to this axis

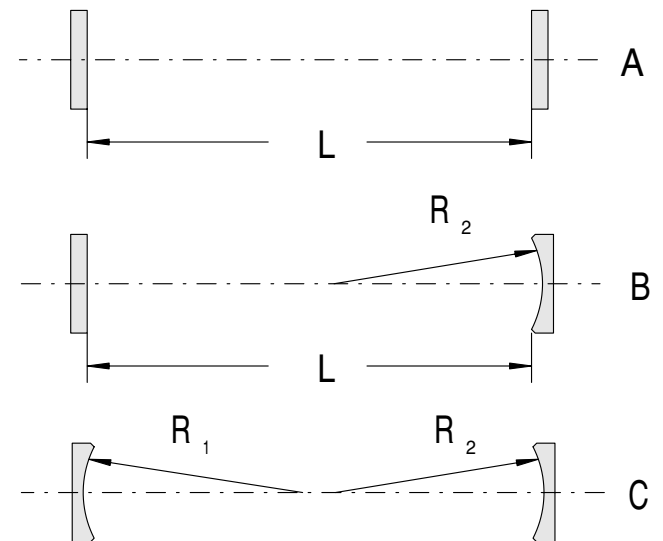

Fig. 2.1: Types of resonator

There are basically three different types of optical resonators:

- plane parallel resonator** **A**
- hemispherical resonator** **B**
- spherical resonator** **C**

For lasers in the low to medium power range (1 mW-200W), the hemispherical resonator is mainly used. Its features include high output powers with relatively uncritical mechanical adjustment. Apart from other parameters, the output power depends on how much of the laser-active material is used. In this respect the terms pump volume and mode volume are used. The pump volume is the volume of the active material which is illuminated by the pump radiation. In contrast the mode volume is the volume which the laser modes fill within the laser-active material. By selecting the focusing, the pump radiation and the resonator shape the designer can influence both quantities. In the optimum case the pump volume should be a little larger than the mode volume. The mode volume de-

depends on which beam parameters are chosen within the laser resonator. These parameters are determined by the selection of the type of resonator, the radius R of curvature and separation L of the mirrors. However, it should be noted that within certain limits the separation L of the mirrors cannot be varied at will for a given radius R of curvature.

2.2 Stability criterion

The range in which a resonator configuration exhibits any kind of optical stability is found by the stability criterion. A resonator is optically stable if, after any number of reflections, the light still remains in the resonator due to the imaging characteristics of the mirrors used and does not leave the resonator by protruding beyond the edges of the mirrors. For the plane parallel resonator (A), in which the light beam is only reflected and not modified in shape, it must be ensured that both plane parallel mirrors are adjusted exactly parallel to one another. This type of resonator is the most difficult to adjust and to maintain in a correctly adjusted condition. The spherical resonator (C) is the most simple to adjust, but has the disadvantage that undesired transverse modes can easily start to oscillate. This means that the laser power is split up over a number of modes which are separated spatially from one another and which cannot be focused to a common point as with longitudinal modes.

The hemispherical resonator represents a satisfactory compromise and the stability range for this type of laser is determined in the following. First of all, the g parameters are defined.

$$g_i = 1 - \frac{L}{R_i} \quad \text{g - Parameter}$$

L is the mirror separation and R is the radius of curvature of the laser mirror. The index i is 1 for the left mirror and 2 for the mirror on the right side. If the product $g_1 g_2$ satisfies the condition

$$0 \leq g_1 \cdot g_2 \leq 1 \quad \text{stability criterion}$$

then the resonator is optically stable and the light, once produced, does not leave the resonator by passing over the edges of the mirror. Instead the light remains within an upper limit referred to a distance parallel to the optical axis of the resonator. The stability diagram for the case of interest here is shown in Fig. 2.2 for the hemispherical resonator.

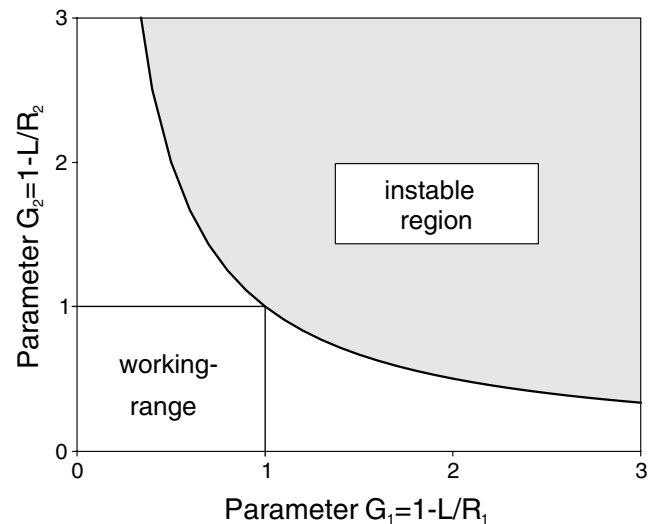

Fig. 2.2: Stability diagram

For this resonator $g_1=1$, since $R_1 = \infty$ (plane mirror). All resonators are unstable above the limiting curve $g_1 g_2 = 1$ and are stable below this limit. Since $g_1 = 1$, then with a fixed R_2 the distance of mirror 2 can only be changed from $L=0$ ($g_2 = 1$) to $L=R_2$ ($g_2 = 0$). The distance that is actually adjusted within this range depends on the application for which the laser is to be optimised for. The closer the resonator is operated to the stability limit, then the more sensitive it is to maladjustment, because even small changes in separation can take the resonator into the unstable region (e.g. thermal expansion). The mirror separation can be decreased to prevent this problem, but the mode volume is reduced and this in turn significantly affects the output power of the laser.

2.3 Resonator modes

2.3.1 Longitudinal modes

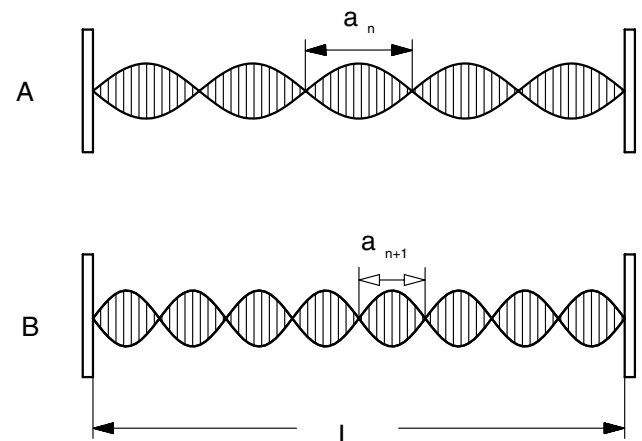

Fig. 2.3 : Standing waves in a resonator with plane parallel mirrors. In the upper example five longitudinal modes fit into the resonator of length L and in the lower one $n=8$

The light-wave is reflected at the mirrors and returns along the same path. The electric field strength of the wave is therefore zero at the mirrors. For a certain separation L of the mirrors only waves can be formed which have a field

strength of zero at both mirrors. Obviously, this is possible for a large number of waves for which an integer number n of their half wavelengths $\lambda/2$ fit in the resonator Fig. 2.3. The waves which fit into the resonator are termed oscillating modes or simply modes. If this integer number is n , then all waves fit into the resonator for which

$$n \cdot a_n = L$$

is true. The next neighbouring mode fulfils the condition

$$(n + 1) \cdot a_{n+1} = L$$

The separation between the wavelength of two neighbouring modes is $2a_{n+1} - 2a_n$. If λ is the wavelength, ν the frequency and c the velocity of the wave, then the following applies with:

$$a_n = \frac{\lambda_n}{2} \quad \text{and} \quad \nu = \frac{c}{\lambda}$$

$$|\delta\lambda| = \left| \lambda_{a(n+1)} - \lambda_{a(n)} \right| = \frac{2 \cdot L}{n \cdot (n+1)}$$

or:

$$\delta\nu = \frac{c}{2 \cdot L}$$

The magnitude of $\delta\nu$ is termed the mode spacing. For a resonator with a length L of e.g. 50 mm, the mode spacing $\delta\nu$ amounts to 3 GHz. In principle there are a very large number of modes which can fit into the resonator. However, the laser-active material can only amplify a certain limited range of these modes. For the Nd-YAG laser the wavelength at which the maximum gain occurs is 1064 nm. The region in which amplification takes place is given by the gain bandwidth (similar to the emission bandwidth). It should therefore be expected that for a resonator length of 50 mm with a mode interval of 3 GHz, 30 longitudinal modes will start to oscillate and the laser emission should consist of a combination of discrete frequencies. From the model of the rate equations we already know that in the steady-state operation of the laser the inversion is reduced until its threshold is reached and that the excess pump photons are converted into laser light. This also means that the gain reaches the value at which the losses are just compensated. According to Fig. 2.5 this would be a horizontal straight line touching the gain curve at its maximum. In this picture only one mode would be able to oscillate, i.e. the one situated closest to the point where the line and curve meet. Just this one mode would take the complete inversion by itself in a "winner takes it all" manner.

2.3.2 Gain profile

Laser materials which consists of atoms or molecules with different properties behave in a different manner. This is particularly noticeable in the situation with gas lasers, e.g. the He-Ne laser, in which the atoms, to a certain extent, move freely in a discharge tube.

Following the Maxwell-Boltzmann distribution, there are groups of atoms which have different velocities. These different groups represent their own classes and gain profiles. The whole gain profile is no longer homogeneous

but is instead inhomogeneous. These types of laser principally oscillate on a number of modes (multimode operation).

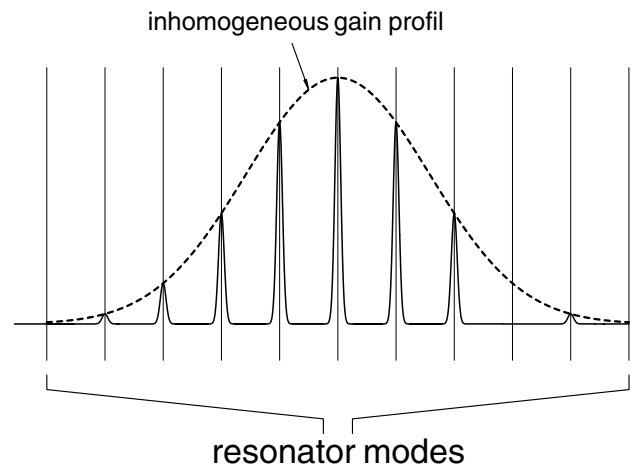

Fig. 2.4: Inhomogeneous gain profile with shown resonator modes. Each individual mode has almost independent operating conditions within the group

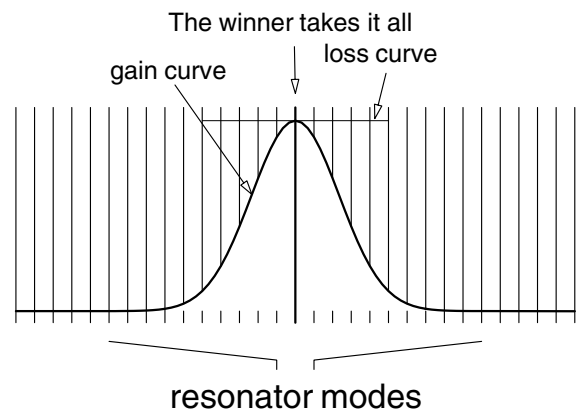

Fig. 2.5: Homogeneously broadened gain profile with shown resonator modes

However, experience has shown that there are no purely homogeneous or inhomogeneous systems. Therefore, the gain profile of the Nd-YAG laser is mainly homogeneous, it also has smaller inhomogeneous parts which lead to the Nd-YAG laser oscillating multimode. Optically pumped systems with homogeneous gain profiles are particularly susceptible to variations in pump power and to disturbances in the resonator length due to vibration, noise, etc. The gain characteristic of the system resonator/laser material is modulated by these types of effects and additional modes can occur. This effect is in fact exploited to generate modes which are coupled together. This method of operation is termed mode locking due to gain modulation. Very short laser pulses in the picosecond region can be produced using this type of operating.

2.3.3 Transverse modes

For the sake of simplicity, the laser and resonator properties were discussed for an example of a plane parallel resonator. In practice this type of resonator is not used due

to its disadvantageous characteristics.

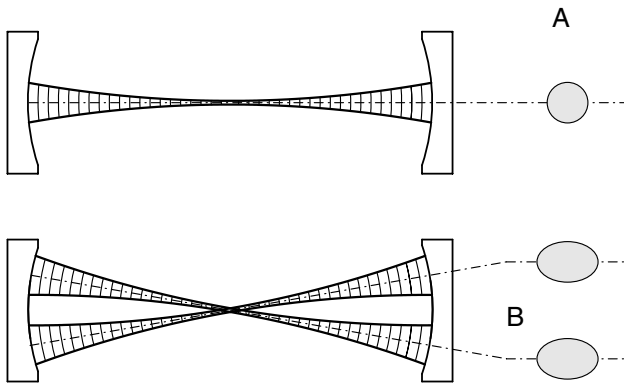

Fig. 2.6: A spherical resonator with oscillation in the fundamental TEM_{00q} (A) and a transverse mode TEM_{01q} (B)

The hemispherical resonator has become very popular, since it exploits in a special manner the desired mode characteristics of the plane parallel resonator and the advantages of adjustment associated with the spherical resonator. However, a disadvantage accompanies this advantage. Whereas almost exclusively longitudinal modes excite in the plane parallel resonator, transversal modes can also arise in spherical resonators. This effect is shown in Fig. 2.6. In contrast to Fig. 2.3 showing the standing waves in the diagram of the electric field of the laser beam, here the geometrical shape of the beam within the resonator is illustrated. When the laser operates in the steady state, the wave-fronts at the mirrors have the same radius of curvature as the mirrors themselves. The situation is drawn in case A in which a radiation field has formed symmetrically about the optical axis. At the resonator output one can see a round Gaussian shaped intensity distribution. But it is also possible for a radiation field to be set up at an angle to the resonator's optical axis. In principle a multitude of this type of radiation field can develop, because in all of these cases the radius of curvature for the radiation field at the mirrors is the same as that of the mirrors. At the resonator output one can now observe intensity distributions spatially separated and no longer symmetrical about the axis of radiation. Since these modes do not oscillate in the direction of the optical axis (longitudinal) but are mainly transversal, these modes are termed transversal modes. Owing to the large number of modes, a convention has been adopted in which the relevant modes are given a universal designation:

TEM_{m n q}

TEM stands for **T**ransverse **E**lectromagnetic **M**odes. The indices m , n and q are integer numbers which state the number of intensity spots minus one in the X axis (m) and the number in the Y axis (n) which are observed. The basis for this consideration is the fundamental mode TEM_{00q} which produces just a round spot. In the example in Fig. 2.6 (B) the designation is:

TEM_{01q}

The number q states how many nodal points the standing wave in the resonator has. This number does not have any significance for the user of the laser and is therefore generally omitted.

3 The pump-light source

Highpower Nd-YAG lasers are still mainly pumped with discharge lamps. Commercially available laser systems can output up to 2,000 watts of continuous-wave laser power. If one bears in mind that the overall efficiency of the Nd-YAG laser is about 1 - 2%, then the discharge lamps must have a light output power of approximately 100 - 200 kW. From the light produced, only 2,000W is converted into laser power and the rest appears as heat which must be extracted using complicated cooling systems. The reason for this "poor" efficiency is that the light produced by the discharge lamps has a broad spectral distribution and the Nd-YAG crystal can only accept the offered light in a number of narrow absorption bands. Up to the present time it has not been possible, in spite of complex and intensive research, to develop discharge lamps which have an emission tuned to the absorption bands of the Nd-YAG crystal. Along these lines, the gas, which is excited in the discharge lamps, has been doped with additives to produce preferred spectral emissions.

3.1 Diode Laser

Laser diodes do not have this disadvantage since they emit intensive laser light in a narrow spectral range of only a few nanometers. The wavelength of diode emission therefore matches an absorption band of the Nd-YAG crystal very well. It is possible to achieve efficiencies of 50-80% in this manner. However, there are not at present any laser diodes available with output powers greater than 10W. On account of the attractive features of laser diodes which, in contrast to discharge lamps, do not require any heavy duty power supplies for high voltages (app. 1000V), intensive research has started in the manufacture of high-power laser diodes. A further advantage of laser diodes is their very small size which enables a large number of individual diodes to be integrated on one common chip. Rows of pump-light sources with optical output powers into the kW region can be built up with this type of laser diode arrays. The laser diodes are a special class of lasers. They differ from "conventional" lasers in two points: Firstly for the classical lasers the laser-active atoms (molecules or ions) are independent of one another and only the same energy levels are used for the laser process. This means in principle that in order to produce a population inversion an infinite number of atoms can contribute (Boltzmann statistics). This is not the case with semiconductor lasers. Here a defined energy level can only be occupied by two active particles (electrons, Pauli Principle). But in semiconductors, the wave functions of the individual atoms overlap to form a common energy band and the extent to which the level is occupied follows the Fermi Dirac statistics. When considering the laser process, the transition between the distribution of population in two energy bands instead of two energy levels must be taken into account as for conventional lasers. The second important difference concerns the propagation of the laser light within the pn zone. The spatial intensity distribution of the laser beam is defined by the laser medium and not by the resonator as for normal lasers.

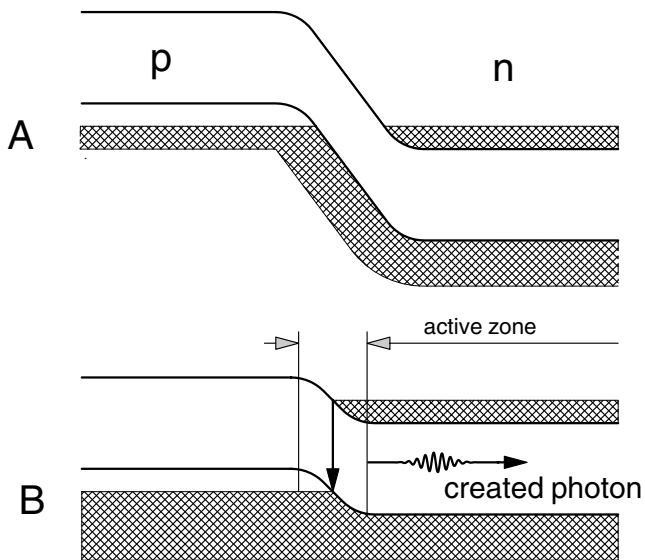

Fig. 3.1: pn junction without applied voltage (A), with applied forward voltage (B). The active zone contains both electrons and holes which produce a photon when recombining.

These two points lead to the fact that the beam characteristics and the spectral properties of semiconductor lasers are significantly different from those of conventional lasers:

For 1.) Laser diodes do not have any inherently defined emission wavelength, because there are no two discrete energy levels that are responsible for the laser process as with traditional lasers, but rather an energy distribution of electrons in energy bands.

For 2.) The production and guidance of the laser light takes place in a very narrow space (pn layer). In contrast to the conventional laser, the dimensions of the resonator are about the same order of magnitude as the wavelength of the laser beam. The spatial distribution of the laser beam and the mode structure is defined by waveguides, whereas the light is freely propagating within a resonator of a conventional type of laser. These two points influence the application of laser diodes.

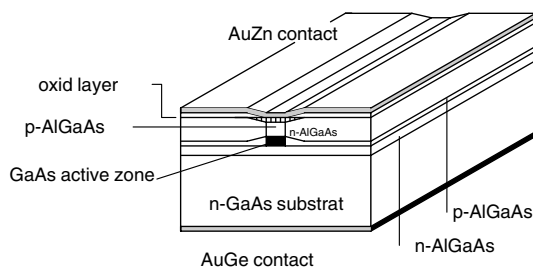

Fig. 3.2: (GaAl)As semiconductor laser with double heterostructure and single stripe geometry

Before the laser beam from laser diodes can be used in the usual manner, the strong divergence must be corrected by sometimes complex optical systems. Also, the corrected parallel beam does not have a round cross-sectional shape, but is elliptical and sometimes almost rectangular. The corrections required to the beam of a laser diode and the difficulties in obtaining the required focusing characteristics with comparable power densities mean that the expense involved in the optics obviates the cost advantages of laser diodes. Because of this, a way is sought of using

the laser diode, not as a primary high power laser, but instead, due to its excellent other characteristics, as a pump-light source for conventional laser systems. It should also be mentioned that the above arguments are only relevant when considering laser systems with high powers for applications in material processing. Without a doubt, laser diodes are excellent as primary lasers in communication techniques. Fig. 3.2 shows a diagrammatic representation of a (GaAl) As semiconductor laser with double heterostructure and single stripe geometry. Charge carriers are injected into the very thin (approx. $0.2 \mu\text{m}$) active layer by applying a voltage via the upper AuZn contact stripe which is only a few μm wide. The active zone is embedded between two heterojunction boundaries which act as barriers for the charge carriers. If the flow of current is high enough, population inversion is formed in the active volume. The laser beam leaves the active zone through the exit window. The crystal has such a high index of refraction that the end surfaces have a sufficient degree of reflection so that no further coating is required and they therefore act as laser resonator mirrors. There are a large number of types of diode lasers which differ in their structure. Only multiple stripe laser diodes, known as diode arrays, are available at present as high-power laser diodes with powers from 3 W upwards. Single stripe diodes (Fig. 3.2) are currently limited in their output power to about 3 W. Output powers of up to 100 W can be achieved by rows of a number of active zones on one chip. The closer the separation between the stripes, the lower the laser threshold will be.

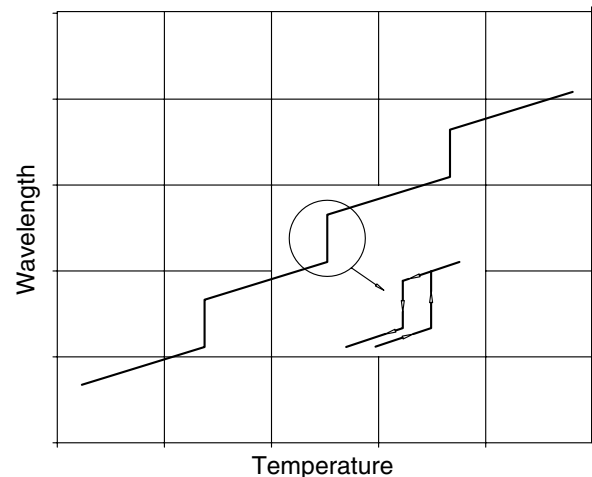

Fig. 3.3 : Emission wavelength in dependence of the laser diode crystal temperature showing a hysteresis

With a sufficiently high gain "supermodes" are created which correspond to one oscillation state for the coupled active zones. The beam profile of the supermode is dispersed according to the extent of the stripe. A laser diode with a single stripe and an output power of 500 mW is used for the Nd-YAG experimental laser. A further characteristic of the diode laser is the strong dependence of the laser wavelengths on the temperature of the semiconductor laser (app. $0.25 \text{ nm}/^\circ\text{K}$) and of the injection current (app. $0.05 \text{ nm}/\text{mA}$). Users who need a defined wavelength must maintain the temperature and the injection current constant to the required values. The wavelength of the laser beam

can be changed by altering the temperature. The wavelength increases with rising temperature. This is due to the fact that with rising temperature the refractive index and the length of the active zone, and therefore of the resonator, are increased.

Above a certain temperature the mode no longer fits into the resonator and a different one oscillates for which the conditions are now more favourable. Since the mode interval of the extremely short resonator (typically 300 μm) is very large, the mode jump is about 0.3 nm. If the temperature is reduced, the laser jumps back in its wavelength again. The return jump does not necessarily take place into the initial mode.

Applications which rely on correct variable tuning of the wavelength of the laser diode should be carried out in a region of the curve in Fig. 3.3 that is remote from any jumps. Similar behaviour is also observed when the injection current, and therefore the laser output power, is varied. Here the change in wavelength arises mainly due to the increase in the refractive index which in turn is due to the rise in charge carrier density in the active zone. With higher output power the temperature also rises due to losses in the form of heat in the active zone. The dependence of the current, and therefore the output power, on the temperature is typical for semiconductors (Fig. 3.4). It is therefore essential that in practical operation the beam power is continually monitored.

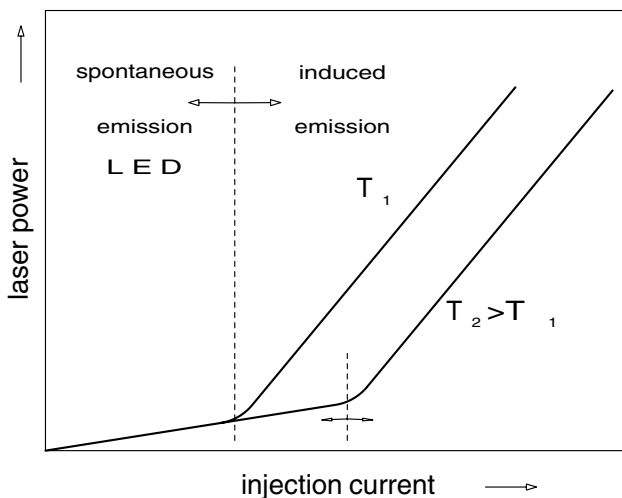

Fig. 3.4: Dependence of Laser power on the injection current with the temperature as a parameter

To achieve this, a photodiode is built into the laser housing and the photodiode supplies a signal which is independent of temperature and which is proportional to the beam power. This signal is used as input for a control circuit with which the laser current is corrected and laser power maintained constant.

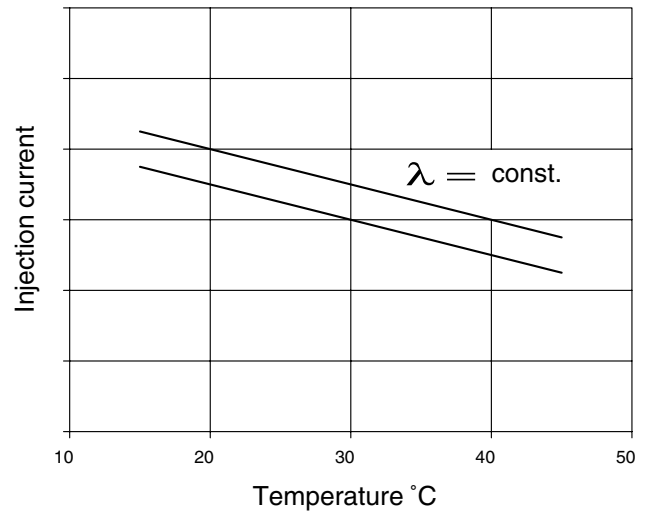

Fig. 3.5: Injection current versus temperature for constant wavelength, shown for two different wavelengths

The wavelength of the laser diode can be expressed as a function the two variables temperature T and injection current I in the following equation:

$$\lambda(T, I) = \lambda(T_0, I_0) + \alpha_T \cdot (T - T_0) + \alpha_I \cdot (I - I_0) + \alpha_T^2 \cdot (T - T_0)^2 + \alpha_I^2 \cdot (I - I_0)^2 + \dots + \alpha_T^n \cdot (T - T_0)^n + \alpha_I^n \cdot (I - I_0)^n$$

For practical considerations it is sufficient to use only the linear terms of the above equation. This approximation is good for $\delta\lambda/\lambda > 10^{-6}$. For operation at constant wavelength, $\lambda(T, I) = \text{const.} = \lambda_c$, the equation can be written as:

$$I = I_0 + \frac{1}{\alpha_T} (\lambda - \lambda_0) + \frac{\alpha_T}{\alpha_I} \cdot (T - T_0)$$

Once this curve is measured as it will be done later, the important coefficients α_T and α_I can be determined.

4 Second Harmonic Generation

4.1 Introduction

The saying “to shed light upon a matter” means, more or less, to “illuminate” facts that are unclear. In 1644 Rene Descartes published his metaphysical ideas on the essence of light. Since then, people have been trying to shed light upon “light” itself. According to his ideas, light consists of scattered particles which have different speeds in different bodies. In 1667, R. Hooke claimed that this was all nonsense. He was the first person who thought that light consisted of quick oscillations. Huygens demonstrated light ether in 1690. In 1717 Newton proved that light has a transversal quality. At that time, however, people could only imagine longitudinal waves, so Newton rejected the wave theory of light completely. Newton’s authority over the subject prevented the formulation of the wave theory of light for 100 years. Unaffected by the dispute over the

essence of light, James Clerk Maxwell summarised the electrical and magnetic appearances in a system of mathematical equations. In 1856, when Kohlrausch and Weber found out through measurements that the speed of electromagnetic waves was the same as that of light, Maxwell came to the conclusion that light is an electromagnetic oscillation. In 1888 Heinrich Hertz was able to give experimental proof of electromagnetic waves. As can be easily imagined, due to the various interpretations on the nature of light it took a long time for the electromagnetic theory to be recognised as a basis for the sum of the physical experiences which could not be reduced any further. But, as we now know, even this theory has its limitations. It is possible to explain all appearances which occur in light scattering using this theory. However, it fails in the case of the emission and absorption of light. Max Planck was able to solve the problems in this area with his formula $E = h\nu$. According to this formula light possesses both qualities, i.e. corpuscular as well as wavelike qualities. This paradoxical formula could finally be clarified through quantum mechanics. There was a further change in classic optics in the sixties of this century when lasers were discovered. For the first time, light was subjected to an unusually high intensity. People observed appearances such as the optical frequency doubling which led to the formulation of non-linear optics. In classic, i.e. linear optics, the scattering of light in matter is described by both optical constants dependent on the frequency, the refractive number n and the absorption coefficient α . In present linear optics, these variables are independent of the intensity of the light falling in. Reflection, refraction, scattering speed and weakening of light are therefore constants of the relevant medium and are not dependent on the light intensity. This resulted in two important principles used everywhere in optics: The superimposition principle (interference) and maintaining the frequency. Both these conditions are only valid in relatively small light intensities as can be obtained from normal light sources. Neither the superimposition principle nor the conservation of frequency apply to the high intensities of lasers. Therefore, linear optics is only specifically applicable to small light intensities. The following explanations concern optical frequency doubling as it is carried out later with the radiation of a Nd YAG-Laser.

4.2 Interaction of light and matter

The appearances observed on the basis of the interaction between light and matter can, in principle, be divided into two groups.

- A. resonant phenomena
- B. non-resonant phenomena

In the case of resonant light the incoming radiated light has an energy of $E = h\nu$, which corresponds to the energetic distance of a transition. Electrons of the atoms or molecules in their original position are transferred to E_1 which is in an excited state. In the example of non-resonant light, the energy of the incoming radiated light is much smaller than the energetic interval of the observed transition.

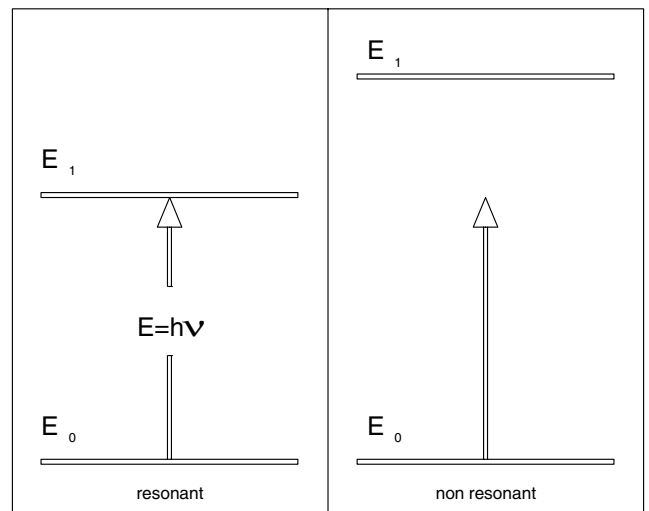

Fig. 4.1: Incoming radiated light is resonant to a transition of the sample (left) and non-resonant (right) for a material with another transition

There is still an interaction, in which, however, no transition of the electrons takes place. The interaction occurs through the electromagnetic property of light together with the electromagnetic property of matter. We now want to promote the fact that our material does not conduct electricity and that it is not magnetic. This is the case for almost all optically transparent materials from which components suitable for optics, such as lenses, prisms, crystals etc. are made. The interaction of light is reduced on the electrical qualities by the selection of the material. These qualities are described using Maxwell's equations.

4.3 Non-linear Optics

For a more vivid explanation it is helpful to imagine the electrons as elastic particles bound to the nucleus.

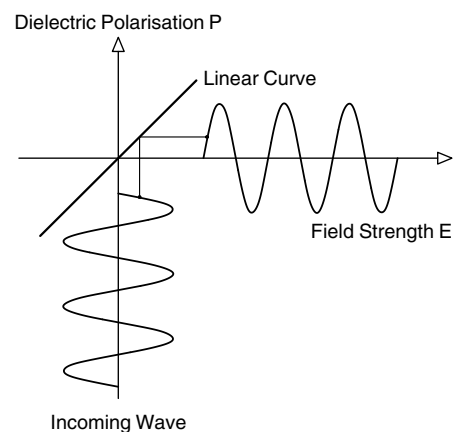

Fig. 4.2: Displacement of the electrons through an electrical field E

An electrical field drives the electron out of its position of rest and produces a dipole (or changes an already existing dipole). If the electrical field is periodic, then the driving out process (dielectric polarisation) will also be periodic and the dipole will radiate with the same frequency as the electrical field producing it but with a phase shift. This phase shift is responsible for the fact that the phase speed of light in matter is apparently slower than in a vacuum.

The photons do, in actual fact, always move at the speed of light in a vacuum. There is, of course, a vacuum between the atoms. The starting point for radiation in a medium are the incoming radiated photons which for their part, excite the dielectric polarisation dipoles. These pass on the radiation with a phase shift from dipole to dipole. If the entering photons had to be marked in colour, very few of the coloured ones would appear at the exit of the sample, but a number of the ones that are not marked would exit. When light is radiated into a transparent sample, the electrical field vector of light corresponds to the field E. If the field intensity of the light radiated is increased, so is the displacement of the electrons. The displacement of the electrons depends not only on the field intensity, but also on the "spring constant" of the binding of the electron to the nucleus (susceptibility). If the field strength or the susceptibility is large enough, the displacement becomes so big that the connection between the power and displacement, analogous to the diversion of a spring over the area of proportionality (Hooke's Law), is not linear any longer.

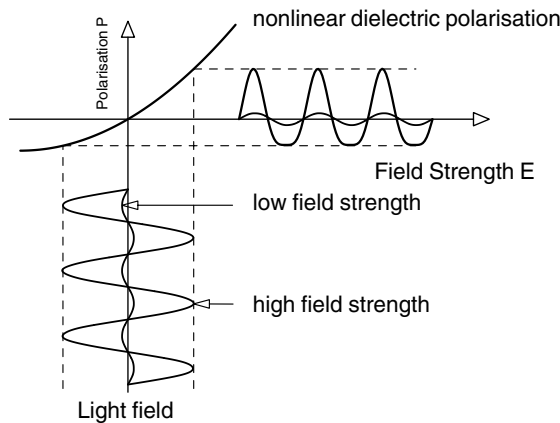

Fig. 4.3 : Increased light field

The polarisation now contains frequencies which the driving field strength did not originally contain. In the example shown in Fig. 4.2 the polarisation takes place in a linear position to the field intensity according to:

$$P = \chi_L \cdot E \tag{4.1}$$

χ_L is the susceptibility. In the example shown in Fig. 4.3 the relation is not linear any longer, due to the high field intensity, but

$$P = \chi_L \cdot E + \chi_{NL}^2 \cdot E^2. \tag{4.2}$$

Even higher terms occur as the field intensity increases further. The cause for the frequency doubling is, however, the quadratic term. Since electromagnetic oscillation is a result of the polarisation and it is not harmonic, light waves will now occur with frequencies which are not contained in the exciting light.

4.4 Frequency doubling

A Fourier analysis shows that in this case, a further frequency occurs apart from the fundamental oscillation.

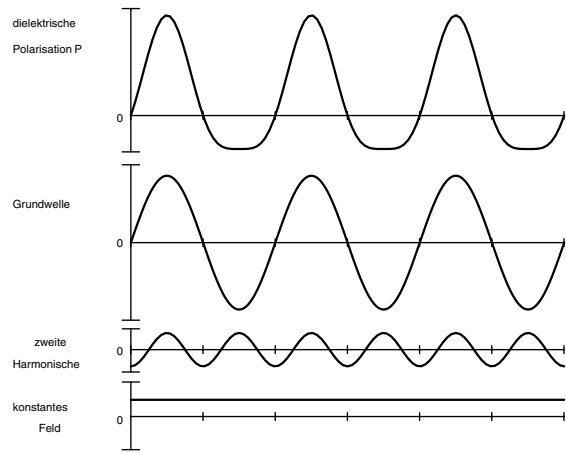

Fig. 4.4 : Occurrence of an oscillation with double frequency and of a constant inner electrical field as well as the original fundamental wave

If, for example, the radiation of the Nd -YAG-laser is transmitted through a suitable doubling crystal, then a radiation of 532 nm occurs apart from the fundamental wave at 1064 nm. This is a green radiation which is very clearly visible. If the intensity of the green radiation is high enough, this can be transferred again with a further crystal in UV radiation at 266 nm. Limits are only set by the availability of suitable doubling crystals. What properties should this kind of crystal possess ? As we can see in Fig. 4.3, the susceptibility, i.e. the scale used for it is very large and an electron can be displaced very easily. It is also important that the electron is in a potential that is strongly anharmonic. This property can be found in some crystals which do not allow the electrons to be displaced evenly in all directions because of their grid structure. Another important factor is that the material should be such that the doubling and incoming waves are not absorbed.

4.5 Phase matching

An important question, is, of course, the degree of effectiveness η_{SHG} , for the production of the doubled radiation. It depends on the variable of a non-linear constant C, on the used length L of the crystal used and on the intensity of the radiation of the fundamental wave.

$$\eta_{SHG} = \frac{P_{2\nu}}{P_\nu} = C \cdot I_\nu \cdot L^2 \cdot F(\delta k) \tag{4.3}$$

$P_{2\nu}$ denotes the power of the doubled radiation,

P_ν the power of the fundamental wave,

$I_\nu = P_\nu / A$ the intensity of the fundamental wave, or the power P with regard to the beam cross section A and L the length of the crystal.

$$F(\delta k) = \frac{\sin\left(\delta k \cdot \frac{L}{2}\right)}{\left(\delta k \cdot \frac{L}{2}\right)^2} \tag{4.4}$$

$F(\delta k)$ is a function whose value and thus the degree of efficiency becomes maximum when $\delta k = 0$, i.e.

$$\delta k = k_{2\nu} - k_{\nu} = 0$$

$k_{2\nu}$ is the wave number of the doubled wave and k_{ν} is the wave number of the fundamental wave. When $\delta k = 0$ the so called phase matching condition is fulfilled. This can be easily concluded from the following observation. Let us assume, for the time being, that the doubling crystal is a black box and let us look at the conservation of energy and impulses.

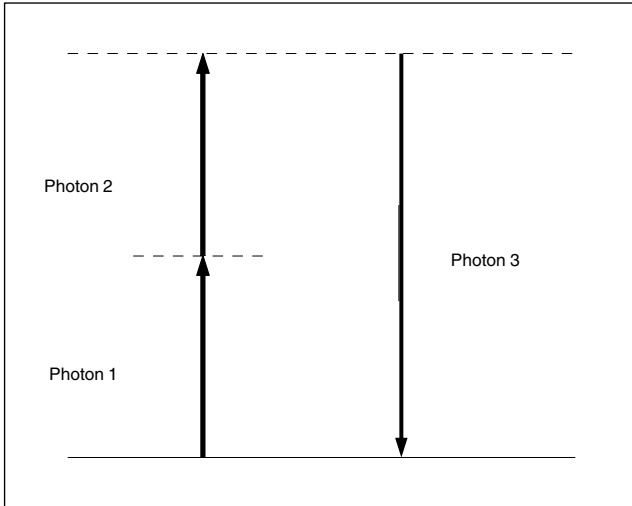

Fig. 4.5: Formation of photon 3 from photon 1 and 2

Photon 3 is formed out of the photons 1 and 2. Since photons 1 and 2 are identical to the frequency doubling in this case, photon 3 possesses the energy

$$E_3 = E_{2\nu} = E_1 + E_2 = 2 \cdot h \cdot \nu \quad (4.5)$$

The conservation of the impulses is also the same since there is no other mechanism that can take an impulse J .

$$J_3 = \frac{h}{2 \cdot \pi} \cdot k_{2\nu} = J_1 + J_2 = \frac{h}{\pi} \cdot k_{\nu} \quad (4.6)$$

This means $k_{2\nu}$ has to be equal to $2 k_{\nu}$ for a correct energy and impulse balance. The frequency doubling occurs with the highest degree of efficiency when the sum and the direction of the impulses are maintained.

Since $k = \frac{2 \cdot \pi}{\lambda}$ in vacuum and $k = \frac{2 \cdot \pi}{n(\nu) \cdot \lambda}$ in matter, the phase matching condition

$$n(2 \cdot \nu) = n(\nu) \quad (4.7)$$

is a result of equation (4.6).

If the index of refraction $n(2\nu)$ of the doubled radiation is the same as the index of refraction $n(\nu)$ of the fundamental

wave, the conversion occurs at the highest degree of efficiency. This is not possible due to the normal dispersion. Therefore birefractive crystals are used with which the various refractive figures of the ordinary and extraordinary beams are exploited. If radiation occurs at a particular angle with regard to the optical axis of the crystal, the condition for phase matching can be fulfilled. This type of matching is known as angle matching and is the type which is mainly used.

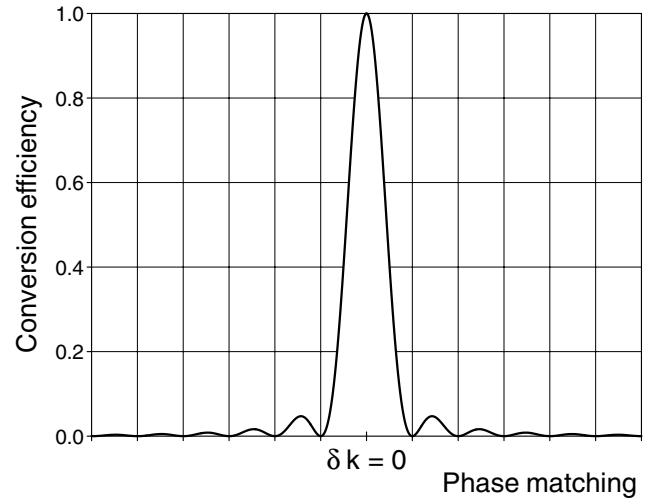

Fig. 4.6: Efficiency of the frequency doubling as a function of phase matching according to Eq. (4.4)

If radiation does not take place exactly at the matching angle the degree of efficiency will be reduced considerably. In the case of deviations within $\pm 2^\circ$ (acceptance angle) we can still observe a frequency doubling, for example, in the case of KTP (Potassium Titanyl Phosphate). In practice the crystals are fixed onto adjustable holders to achieve the best possible degree of efficiency.

A further important aspect for the conversion efficiency is, according to equation (4.3), the intensity of the fundamental wave. Therefore two things must be observed when setting up an experiment:

1. A maximum possible fundamental wave power should be produced.
2. The highest possible intensity should be created through focusing.

This is why the frequency doubling is carried out inside the resonator in a further experiment. The power of a laser is much higher within the resonator than outside. In addition the doubling crystal is positioned in the beam waist. A KTP crystal is used in the experiment as a doubling crystal. KTP stands for the compound $K TiO PO_4$, Potassium Titanyl Phosphate and is a positive ($n_o > n_{ao}$) crystal with two axes. This means that extraordinary refraction occurs in different ways in the X and Y directions. The wavelength dependency of the refractive index is given in the following equations for KTP and in Fig. 4.7.

$$n_x^2 = 2.10468 + 0.89342 \lambda^2 / [\lambda^2 - 0.004438] - 0.01036 \lambda^2$$

$$n_y^2 = 2.14559 + 0.87629 \lambda^2 / [\lambda^2 - 0.0485] - 0.01173 \lambda^2$$

$$n_z^2 = 1.9446 + 1.3617 \lambda^2 / [\lambda^2 - 0.042] - 0.01491 \lambda^2$$

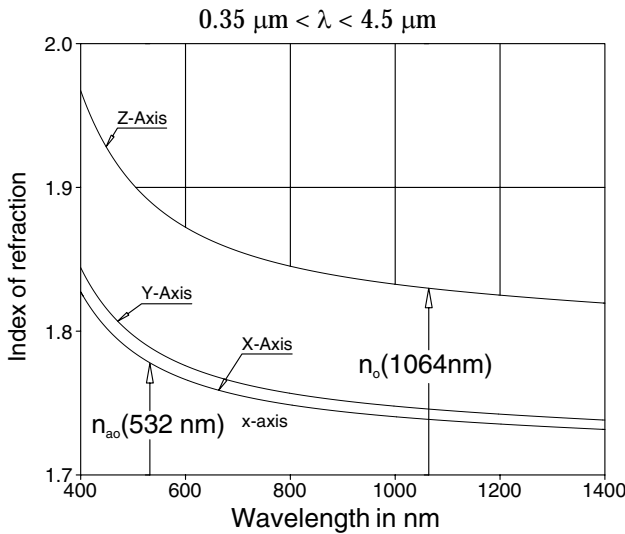

Fig. 4.7: Dispersion of KTP

The condition $n(2\nu) = n(\nu)$ must be fulfilled. This condition can be fulfilled because the value of the extraordinary refractive index depends on the angle θ to the optical axis Z of the KTP crystal whereas the ordinary index does not. If the fundamental wave (laser beam at 1064 nm) is beamed in at a particular angle then $n(2\nu) = n(\nu)$. This angle is given by the intersection of the ellipse $n_{ao}^{2\nu}(\theta)$ with the circle n_o^{ν} (Fig. 4.8).

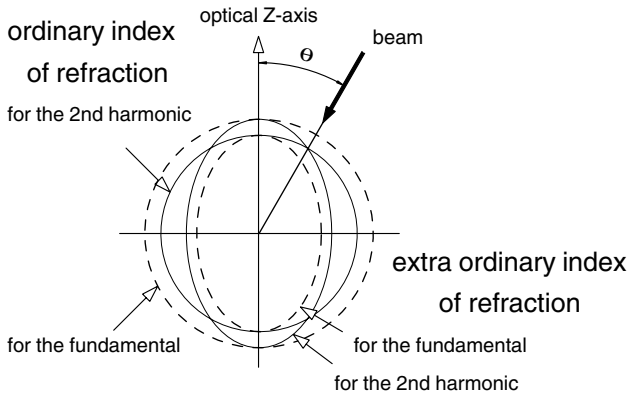

Fig. 4.8: Index ellipsoid and phase matching for $n(2\nu) = n(\nu)$

According to geometric considerations based on Fig. 4.8 the angle θ can be calculated with the following equation.

$$\sin^2(\theta) = \frac{n_o^{-2}(\nu) - n_o^{-2}(2\nu)}{n_{ao}^{-2}(2\nu) - n_o^{-2}(2\nu)}$$

The refractive indices in each case can be calculated from the dispersion curves.

The KTP crystal is then cut in such a way that the laser beam meets the crystal and the optical axis at the angle θ .

Finally we will discuss the power of the frequency doubled wave. Once the phase matching has been ensured,

then

$$P_{2\nu} = \frac{C \cdot L^2}{A} \cdot P_{\nu}^2$$

according to equation (4.3).

After this, the power $P_{2\nu}$ of the frequency doubled wave increases quadratically with the power P_{ν} of the fundamental wave.

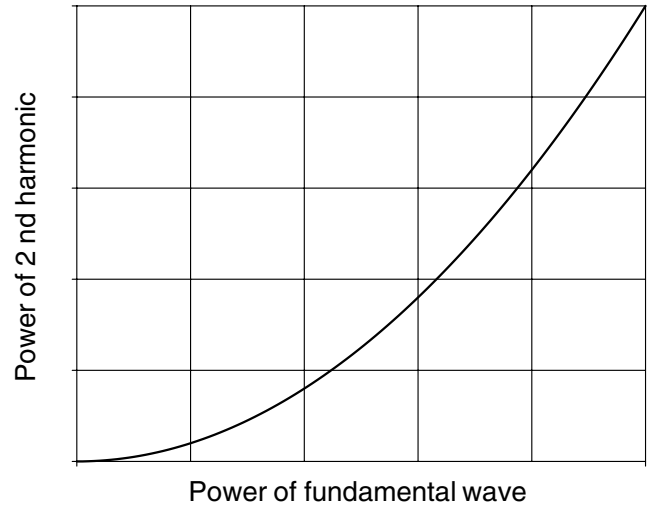

Fig. 4.9: Quadratic relation between the power of the fundamental waves and that of the second harmonic.

Furthermore, it has been determined that there is no threshold in this process. Set-ups and arrangements for the efficient carrying out of the frequency doubling should therefore be selected. These should produce as large as possible powerful fundamental. Since, for example, the Q-switch operation leads to a considerable increase in power, this method is explained in greater detail with the Nd - YAG laser although it will not be carried out in this experiment. We have not yet discussed the constant C in detail.

$$C = 2 \cdot \left(\frac{\mu_0}{\epsilon_0} \right)^{3/2} \cdot \omega^2 \cdot \frac{d_{ik}}{n^3}$$

μ_0 denotes the induction constant, ϵ_0 the influence constant, $\omega = 2\pi\nu$ the angular frequency, n the index of refraction of the crystal and d_{ik} are components of the susceptibility tensor χ . Till now we have considered χ as a number, i.e. the medium observed was isotropic. This is not valid for the crystals used here. We will develop the ideas to the extent that we will accept P and E as vectors.

$$\vec{P} = (P_x, P_y, P_z) \text{ and } \vec{E} = (E_x, E_y, E_z)$$

$$\vec{P} = \chi_L \cdot \vec{E} + \chi_{NL} \cdot \vec{E}^2$$

This means that χ_L and χ_{NL} are now matrices. They are known as tensors because they have the qualities which make it possible to turn and stretch a vector \vec{E} to \vec{P} . We are only interested in the non-linear part.

$P_{NL} = \chi_{NL} [E_x^2 + E_y^2 + E_z^2 + 2E_z E_y + 2E_z E_x + 2E_x E_y]$
In terms of vectors and tensors the above equation would be written as follows:

$$\begin{pmatrix} P_x \\ P_y \\ P_z \end{pmatrix} = \begin{bmatrix} d_{11} & d_{12} & d_{13} & d_{14} & d_{15} & d_{16} \\ d_{21} & d_{22} & d_{23} & d_{24} & d_{25} & d_{26} \\ d_{31} & d_{32} & d_{33} & d_{34} & d_{35} & d_{36} \end{bmatrix} = \begin{pmatrix} E_x^2 \\ E_y^2 \\ E_z^2 \\ 2E_z E_y \\ 2E_z E_x \\ 2E_x E_y \end{pmatrix}$$

KTP is an orthorhombic crystal of the type mm 2 with the following non-linear tensor χ_{nl} .

$$\chi_{NL} = \begin{pmatrix} 0 & 0 & 0 & 0 & d_{15} & 0 \\ 0 & 0 & 0 & d_{24} & 0 & 0 \\ d_{31} & d_{32} & d_{33} & 0 & 0 & 0 \end{pmatrix}$$

The following is the result for non-linear polarisation based on the above equation:

$$P_x(2\nu) = 2 \cdot d_{15} \cdot E_z \cdot E_x$$

$$P_y(2\nu) = 2 \cdot d_{24} \cdot E_z \cdot E_y$$

$$P_z(2\nu) = d_{31} \cdot E_x^2 + d_{32} \cdot E_y^2 + d_{33} \cdot E_z^2$$

According to Fig the phase condition has been adjusted because the fundamental wave runs as an ordinary beam in the crystal at an angle θ to the optical axis. Therefore the fundamental wave does not possess any component which oscillates in the Z direction, i.e. E_z is zero. The second harmonic oscillates as an extraordinary wave out of necessity since $P_x(2\nu)$ and $P_y(2\nu)$ are zero according to the above equations.

$$\Rightarrow P_z(2\nu) = d_{31} \cdot E_x^2 + d_{32} \cdot E_y^2$$

Now $P_z(2\nu)$ has to be maximised. Since $E_x^2 + E_y^2 = E_0^2$ this is fulfilled for

$$P_z(2\nu, \theta) = d_{31} \cdot E_x^2 \cdot \sin(\theta) + d_{32} \cdot E_y^2 \cdot \cos(\theta)$$

$$\frac{E_x^2}{E_y^2} = \frac{d_{32}}{d_{31}} \cdot \frac{\cos(\theta)}{\sin(\theta)} = \tan^2(\phi)$$

For KTP the values of the d_{ik} are:

d_{31}	=	$6.5 \cdot 10^{-12}$	m/V
d_{32}	=	$5.0 \cdot 10^{-12}$	m/V
d_{33}	=	$13.7 \cdot 10^{-12}$	m/V
d_{24}	=	$7.6 \cdot 10^{-12}$	m/V
d_{15}	=	$6.1 \cdot 10^{-12}$	m/V

The azimuth angle ϕ of the incoming beam must be adjusted to the XY axis of the crystal to achieve a maximum power of the second harmonic so that this relationship of the amplitudes towards the crystal axis is adjusted. In practice the crystal is turned around the entering axis of the fundamental wave. Apart from the phase matching we have now taken into consideration the demands placed by the tensor in non-linear polarisation. The condition for frequency doubling is, therefore, that the fundamental wave is polarised in a defined manner. We have, until now, assumed that KTP is a crystal with only one axis. This was to make the observations simpler. There is, however, very

ever, very little difference between both extraordinary refractive indices compared with the ordinary one (Fig. 4.7).

5 Q-switch

One distinguishes between two general kinds of Q-switching. They are termed active if the moment of switching can be determined by the operator and termed passive when the moment of switching is controlled by the laser process itself.

5.1.1 Mechanical Q-switch

At the beginning of the laser technique one uses due to the lack of better methods rotating apertures or laser mirrors as shown in Fig. 5.1. In this set-up a wheel with laser mirrors ground on the wheel turns with an angular velocity ω . If one of the mirrors is in exact position with respect to the optical axis of the resonator the Q reaches its maximum. In all other cases "the resonator is not a resonator"

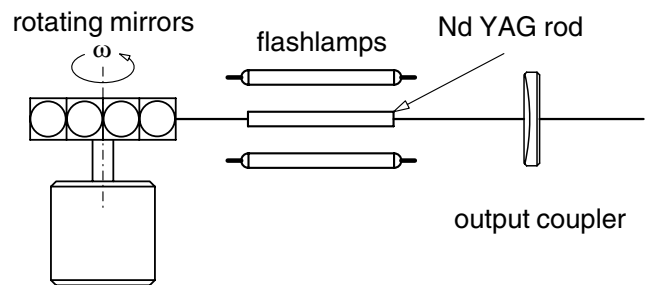

Fig. 5.1: Mechanical Q-switch with rotating mirrors.

5.1.2 Optical Q-switcher

These more modern proven devices are until nowadays in use.

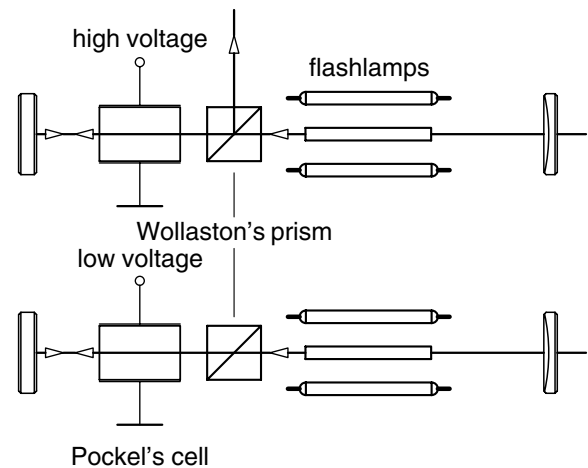

Fig. 5.2: Electro-optic Q-switch device

The Pockel's cell consists of a crystal which becomes birefringent under the influence of an electrical field. At a certain voltage this crystal acts as a quarter wave plate. The light (stimulated emission) which has a defined state of polarisation due to the polarising beam splitter passes through the cell. Depending on the applied voltage to the cell the light stays inside the resonator (high Q) or it leaves it via the beam splitter (low Q). This set-up is mainly used for pulsed (flash lamp pumped) Nd YAG la-

ser. For cw YAG laser with only a few percent of output coupling the damping of the above device is not sufficient for secure suppressing of laser oscillation. For cw pumped systems the acousto-optic Q-switcher of Fig. 5.3 is better suited.

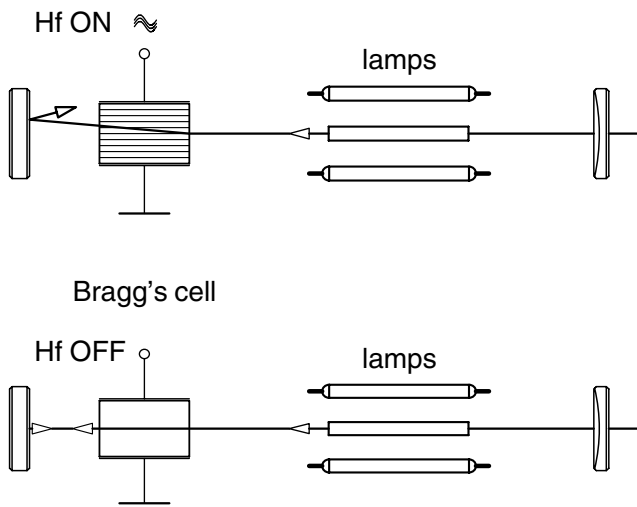

Fig. 5.3: Acousto optical Q-switch device

In this set-up a standing sound wave is introduced by applying a periodic electrical field to a crystal. The generated sound waves produce a periodic compression and decompression of the crystal which leads to a spatial variation of the index of refraction inside the crystal causing a deflection of the passing light. When the applied electrical field is switched off the light travels uninfluenced through the crystal, the Q value now is high.

5.1.3 Passive Q-switch

This technique is used in our latter experiment. Its splendid advantage lies in the fact that these devices are very cheap compared to the active drivers. One only needs a material whose absorption can be bleached under the irradiation of the light from the stimulated emission in a laser resonator. They only have one disadvantage, the timing of the switching can not be controlled as the term "passive" indicates. The effect of bleaching a material by light is explained with the following simple two level rate equation model.

In analogy to the previous rate equation model for four levels the model for two levels is derived. For the level E_1 the change with time of the population density due to absorption is given by:

$$\left. \frac{dN_1}{dt} \right|_{\text{absorption}} = -B_{12} \cdot \rho(\nu) \cdot N_1 = W_{12} \cdot N_1$$

The absorption process populates level 2:

$$\left. \frac{dN_2}{dt} \right|_{\text{absorption}} = B_{12} \cdot \rho(\nu) \cdot N_1 = W_{12} \cdot N_1$$

Processes of spontaneous and induced emission are depopulating level 2 by the rate:

$$\left. \frac{dN_2}{dt} \right|_{\text{spont.}} = -A_{21} \cdot N_2$$

$$\left. \frac{dN_2}{dt} \right|_{\text{induced}} = B_{21} \cdot \rho(\nu) \cdot N_2 = W_{12} \cdot N_2$$

In the stationary case where $dN_2 / dt = 0$ the solution is:

$$\frac{N_2}{N_1} = \frac{W_{12}}{W_{12} + A_{21}}$$

For high values of the pump rate ($W_{12} \gg A_{21}$), N_2 / N_1 becomes approx. 1. This means that the number of absorbed photons becomes the same as the emitted ones. In this case the medium is transparent.

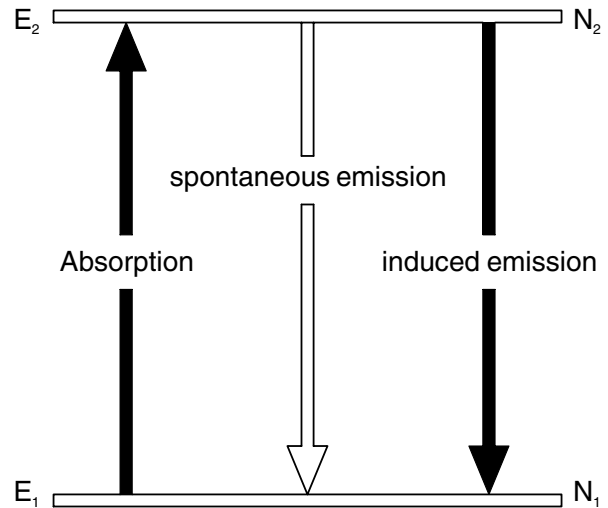

Fig. 5.4: Two level system

All kinds of two level systems can become transparent under the irradiation of light, but they differ in the necessary amount of light intensity. There exist a number of suitable saturable absorbers, for instance dyes in solution or embedded in solids.

These kinds of absorbers have the disadvantage that they are not stable enough for the long times necessary for laser applications. As a suitable candidate Lithium Fluoride (LiF^{2-}) containing x-ray induced colour centres which are responsible for the saturable absorption at 1064 nm has been proven best in the past years. The density of the colour centres has to be chosen in such a way that the laser oscillation is prevented due to the initial absorption.

The increasing stimulated emission starts to bleach the crystal to a value where the laser reaches its threshold. The inserting of laser light drives the crystal to higher transmission. Nearly the complete surplus inversion turns into the photon field inside the resonator and a giant pulse is generated.

After the emission of the pulse the laser oscillation is interrupted due to the reduction of the inversion. The crystal becomes absorptive and the process of bleaching starts again.

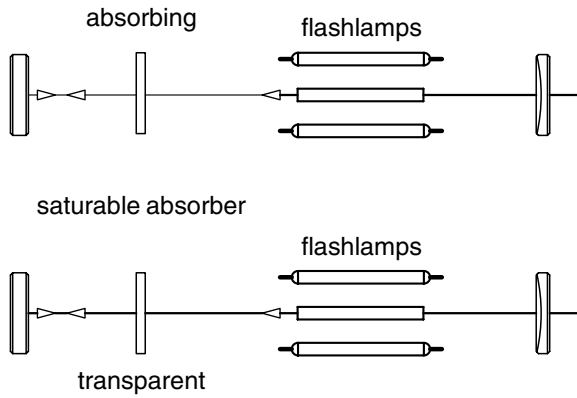

Fig. 5.5 : Passive Q-switch with saturable absorber

5.1.4 Pockel's cell

In the search for an optical switch which could be switched on and off within a few nanoseconds (10^{-9} sec), it soon became clear that no mechanical concepts could be considered. As electrical signals were switched on with corresponding speed, the search was on for an element without any moving mechanical parts, that could follow a very fast electrical field. Many different electro-optical effects which were known for a long time were considered. However, a suitable optical material which on one hand did not require a very high voltage potential and on the other hand was optically very pure, was not found. These qualities were essential because the optical switch was to be used in a Laser resonator and thus its losses had to be very small. Over and above that, extremely high maximum outputs/peaks are produced in a Q-switch, which should not damage the crystal. Already in 1893, Pockels had shown that the addition of voltage on an optical medium, changes its refractive index.

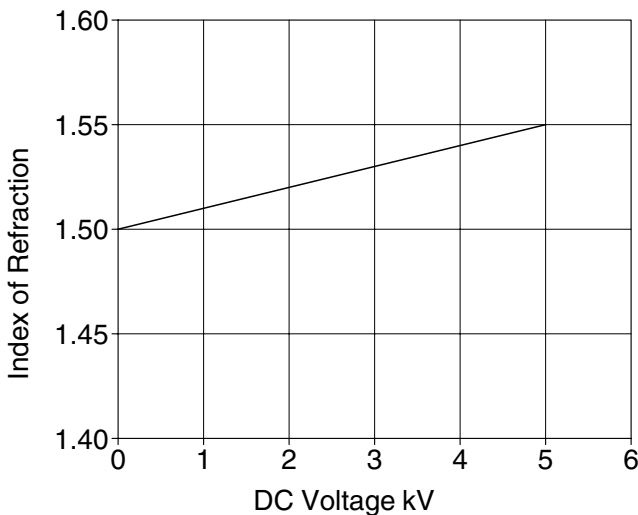

Fig. 5.6 Linear electronic effect(Pockels effect)

$$n = n_0 \cdot (1 + \alpha \cdot E)$$

n_0 is the refractive index without adding outer voltage, α is a material constant and E is the added voltage. However till now we have not realised a switch, as a variation in the refractive index does not cause any change in the amplitude of the intensity of light. When a double refracting crystal is used as an optical medium, then the refractive

index for the ordinary(OR) and the extra-ordinary axis(EO) changes.

$$n^{OR} = n_0^{OR} \cdot (1 + \alpha^{OR} \cdot E)$$

$$n^{EO} = n_0^{EO} \cdot (1 + \alpha^{EO} \cdot E)$$

If the material constants α^{OR} and α^{EO} are different from each other, then the difference in the refractive indices $dn(E)$ is dependent on the given voltage E .

$$dn(E) = n^{OR} - n^{EO}$$

$$dn(E) = n_0^{OR} - n_0^{EO} + (n_0^{OR} \cdot \alpha^{OR} - n_0^{EO} \cdot \alpha^{EO}) \cdot E$$

First we will adhere to this result.

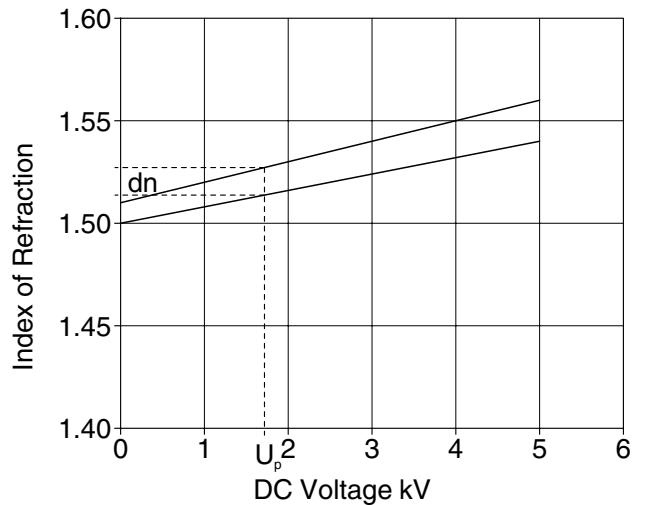

Fig. 5.7: Linear electro-optical effect of a double refracting material.

Let us recall the working of a quarter wave plate (also called the lambda / 4 plate). Such a plate is made up of a double refracting crystal, e.g. natural quartz. Such a crystal is optically not isotropic. Because of its natural crystal-line growth, it has two optical directions which are caused by the asymmetry of the crystal cells.

One can imagine the inner structure of a crystal to be like that of a forest of well ordered antennae. There are as many antennae which receive vertical polarised radiation. These antennae are actually dipoles, which again radiate the received radiation after a certain time.

The light wave falling on the crystal will be taken up by the dipoles, one after the other and then radiated back. The light wave slows down while passing through the crystal. Because of the two types of the dipoles, two different speeds of light are produced in the crystal.

If light with a polarisation of 45° is beamed into an "antennae forest", then the intensity of the light is distributed equally among the dipoles, because the light with the polarisation of 45° can be interpreted as an overlap of orthogonal components.

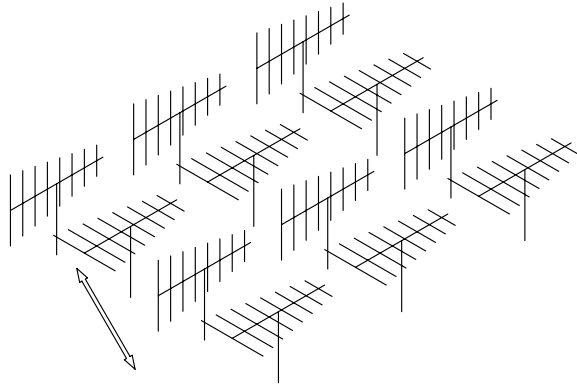

Fig. 5.8: Double refractive crystal as a number of orthogonal dipoles.

At the exit from the crystal, a phase shift is observed between S and P components due to the different speeds of the components in the crystal. Let's refer back to the relation:

$$\frac{1}{n} = \frac{v}{c}$$

where n is the refractive index, v is the speed of light in the medium with the refractive index n and c the speed of light in a vacuum. Because of the two different speeds of light in a crystal, obviously two different refractive indices are existing

$$\frac{v^{OR}}{c} = \frac{1}{n^{OR}} = \frac{\lambda^{OR}}{\lambda}$$

$$\frac{v^{EO}}{c} = \frac{1}{n^{EO}} = \frac{\lambda^{EO}}{\lambda}$$

We use the relation:

$$v = \frac{c}{\lambda} = \frac{v^{OR}}{\lambda_{OR}} = \frac{v^{EO}}{\lambda_{EO}}$$

where v is the frequency of light, λ is the wavelength and λ_m the wavelength in a medium, in which the speed of light is v . Care is to be taken that the frequency is of a sustainable magnitude. The energy E of a light wave is:

$$E = h \cdot v$$

and no energy from the light wave should be given up to the medium. Note: The frequency of a light wave does not change in a medium, only the wavelength, and therefore the speed. This is valid as long as the medium is optically linear. After leaving the crystal, both the partial waves again move with the same speed, which is determined by the refractive index of e.g. Air. But now they have a steady phase shift ρ in respect to one another. As shown in Fig. 5.9, this phase shift ρ depends on the length d or thickness of the crystal. If one chooses the antennae, as also the thickness of the crystal in such a way that the retardation of the phases measures 90° or $\lambda/4$, then two waves which run into each other are produced.

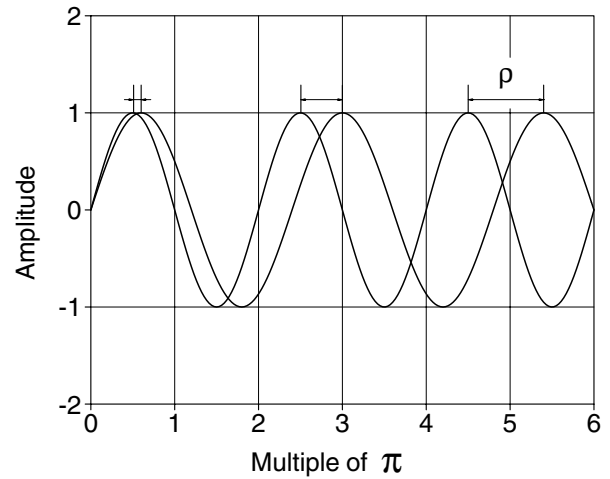

Fig. 5.9: The two waves possess different speeds only inside the crystal

They are polarised perpendicularly with respect to each other and they have a phase shift of 90° or $\lambda/4$ to each other after leaving the crystal. The necessary thickness d here can be calculated easily. For this we use the scalar representation of a light wave moving in a direction x . The number of waves is k with

$$k = \frac{2\pi}{\lambda}$$

ω is the orbit frequency and t is the time

$$E = E_0 \cdot \sin(k \cdot x + \omega \cdot t)$$

For the situation in the crystal, this means:

$$E^{OR} = E_0 \cdot \sin(k_{OR} \cdot x + \omega \cdot t)$$

$$E^{AO} = E_0 \cdot \sin(k_{AO} \cdot x + \omega \cdot t)$$

For the phase shift ρ to correspond to $\lambda/4$, the following must be valid.

$$(k_{OR} - k_{EO}) \cdot d = \frac{\pi}{2}$$

$$\left(\frac{2\pi}{\lambda_{OR}} - \frac{2\pi}{\lambda_{EO}} \right) \cdot d = \frac{\pi}{2}$$

$$\frac{2\pi}{\lambda} \cdot (n_{OR} - n_{EO}) \cdot d = \frac{\pi}{2}$$

$$d = \frac{\lambda}{4} \cdot \frac{1}{n_{OR} - n_{EO}}$$

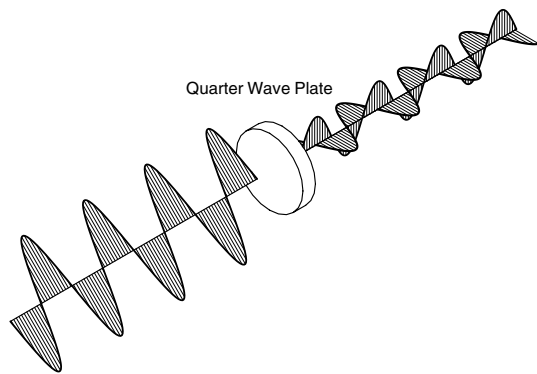

Fig. 5.10: Working of a quarter wave plate

If these intensity components are added as vectors, then the resultant intensity vector rotates with the frequency of the light beam around the axis of radiation. The light is now polarised circular.

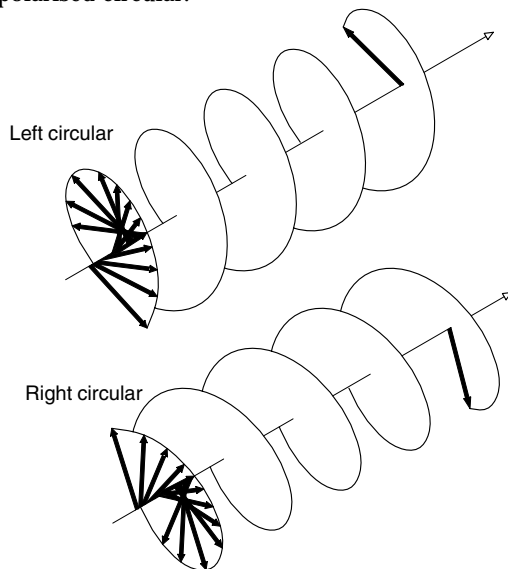

Fig. 5.11: Circular polarised light

Depending on whether the quarter wave plate is met with a irradiation angle of 45° or 135° right or left, circular polarised light is produced. If the thickness of the crystal is chosen for example in such a way that the resultant phase shift measures $\lambda/2$, then one can be certain that the direction of polarisation of the falling light will be rotated by 90° and with a phase shift of λ it will rotate by 180° . All other phase shifts lead to elliptical polarised light. Let us return to the Pockels Cell. Here it is freely possible to change the value of dn by introducing a uniform voltage and thus produce phase shifts as required. The polarisation status of the wave coming out can be electrically directed. If we place a polarisation analyser behind the crystal, we can create such a polarisation direction with the help of an electrical field, so that either no light or all the light passes

the polariser. Furthermore, all the other transmission factors that are desired can also be adjusted with the help of the voltage. So now we possess an element that we can use as an optical switch. We will not be using a polariser in the following experiment, but we will dispose off the polarisation dependent losses in the resonator. For that, a Brewster window is introduced in the resonator, due to which the laser oscillates in a certain direction of polarisation. As is already known from Fresnell's equations, a light ray which enters a Brewster window parallel to the incidence level, experiences no reflection losses. Opposed to that, the losses increase considerably for all other polarisation directions due to reflection. If we introduce a Pockel's cell in the resonator, then we can create another polarisation direction through the variation of voltage in the double refracting crystal, which produces such high losses at the Brewster windows, that the laser cannot oscillate or the oscillation will be interrupted. In this way, it is possible to control the quality of the resonator with the help of a Pockel's cell.