

Related topics

Interference, Doppler effect, scattering of light by small particles (Mie scattering), high- and low-pass filters, sampling theorem, spectral power density, turbulence.

Principle

Small particles in a current pass through the LDA measuring volume and scatter the light whose frequency is shifted by the Doppler effect due to the particle movement. The frequency change of the scattered light is detected and converted into a particle or flow velocity.

Equipment

Base plate with rubber feet	08700.00	1
HeNe laser, 5 mW	08701.00	1
Power supply and switch for 5 mW laser	08702.93	1
Cobra3-BASIC-UNIT	12150.00	1
Power supply, 12 V-	12151.99	1
Data cable, RS232	14602.00	1
Software Cobra3-Frequency Analyzer	14514.61	1
Adjustable holder, 35 x 35 mm	08711.00	2
Surface mirror, 30 x 30 mm	08711.01	2
Magnetic base	08710.00	8
Plate holder	08719.00	1
Lens with mount, $f = +100$ mm	08021.01	1
Lens with mount, $f = +50$ mm	08020.01	1
Lens with mount, $f = +20$ mm	08018.01	1
Iris diaphragm	08045.00	1
Beam splitter, 50:50	08741.00	1

Silicon photo-detector with integrated amplifier	08735.00	1
Control unit for photo-detectors	08735.99	1
Adapter BNC-jack/4 mm-jack pair	07542.27	1
Shielded cable, BNC, $l = 100$ cm	07542.11	1
Prism holder with table	08725.00	1
Lens holder for base plate	08723.00	3
Screen, white, 150 x 150 mm	09826.00	1
Adjusting device, xy	08714.00	1
Pinhole diaphragm, 30 μ m	08743.00	1
LDA-Accessory-Set	08740.00	1
Support rod, "PASS", $l = 650$ mm	02027.55	2
Right angle clamp, "PASS"	02040.55	2
Universal clamp	37715.00	2
Support base, "PASS"	02005.55	1
Aspirator bottle, 1000 ml	34175.00	2
Silicone tubing, $d_i = 7$ mm	39296.00	4
Hose clamp, $d = 10$ mm	43631.10	3
Glass tubes, $d_a = 8$ mm, $l = 80$ mm, 10x	36701.65	1
Rubber stopper with hole	39258.01	2
Rubber stopper with hole	39255.01	2
Measuring tape, $l = 2$ m	09936.00	1
Spatula, stainless steel, $l = 150$ mm	33460.00	1
Glass beaker, 150 ml	36012.00	1
PC, Windows® 95 or higher		

Task

Measurement of the light-frequency change of individual light beams which are reflected by moving particles.

Fig. 1. Complete set-up of the experiment: LDA-Laser-Doppler-Anemometry

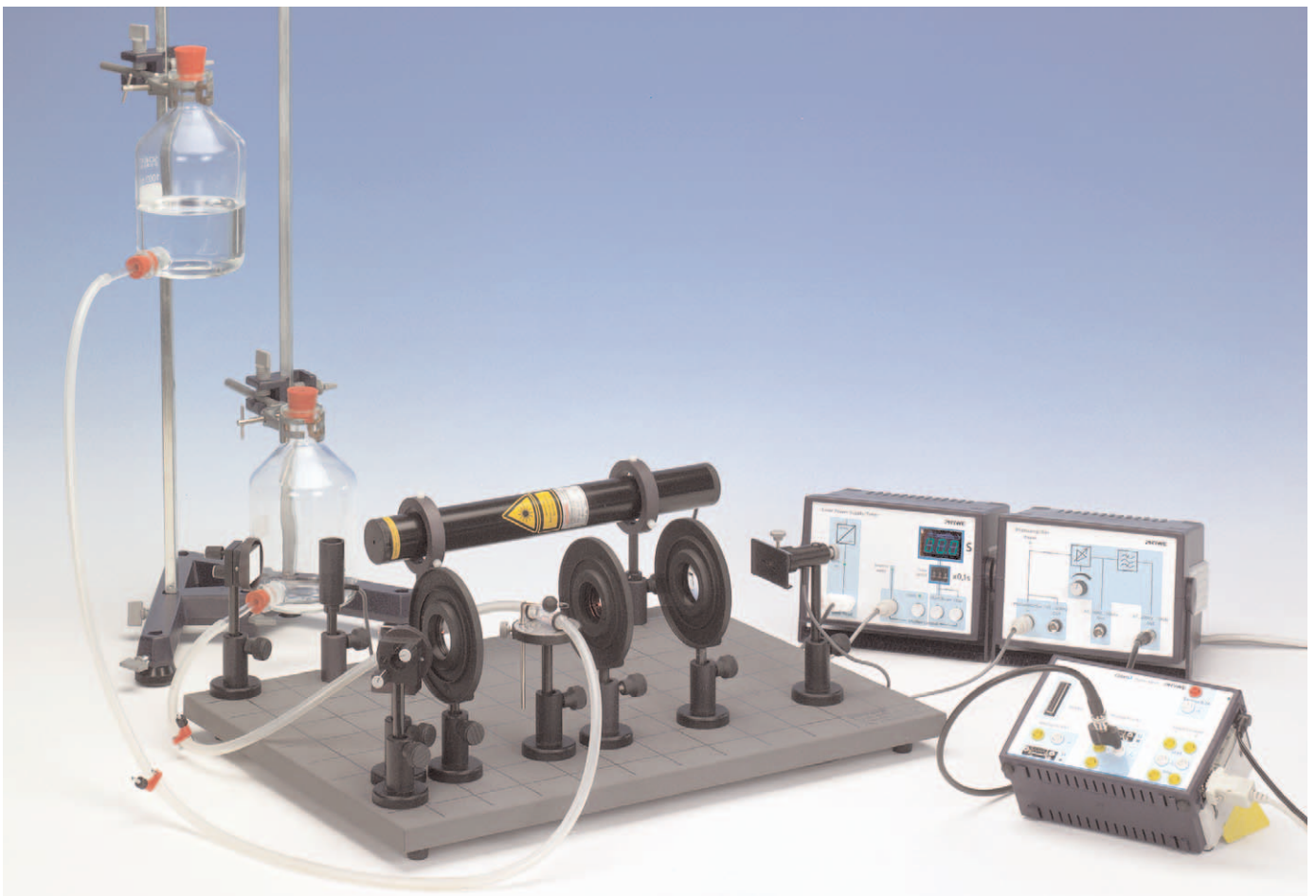

Set-up and procedure

In the following, the pairs of numbers in brackets refer to the co-ordinates on the optical base plate in accordance with Fig. 2. These co-ordinates are only intended to help with coarse adjustment.

Perform the experimental set-up according to Fig. 1 and Fig. 2. The recommended set-up height (beam path height) is 130 mm.

Initial operation of Cobra3:

Start the “measure“-software and select the “Frequency Analysis“ mode. Cobra3 must have been switched on before the program is started. Connect the output of the control unit for the photodetector in the ANALOG IN2 input of Cobra3. For this use the shielded BNC cable and the adapter (BNC-Socket/4mm plug pair). Connect the adapter to + and GND, take the polarity of the adapter into account.

Preparing the liquid:

To begin with mix only a small quantity of distilled water (approximately 10 ml) with a spatula-tip full of silver-coated glass beads in a small vessel. Fill an aspiration bottle, whose lower drain has already been connected to a piece of silicone tubing sealed with a hose clamp, with a quantity of water approximately equal to 500 ml in which approximately 2 to 3 ml of the previously prepared concentrated solution with scattering particles is given. To kill bacteria, it is advisable to add a few drops of formaldehyde (30%).

Setting up the liquid reservoir:

Provide the support base with both support rods ($l = 650$ mm). Attach the glass bottles to the support rods by clamping one of the universal clamps on each of the bottle necks and then using the right-angle clamps to connect them to the rods (see Fig. 1). In the same manner as already performed on the first bottle, now also equip the lower drain hole of the second one with a piece of silicone tubing, which is sealed with a hose clamp to begin with. The pieces of silicone tubing have been slipped onto glass

tubes which have been inserted into rubber stoppers. These, in turn, have been stuck into the lower openings of the aspiration bottles. The upper opening of the aspirations bottles are also to be sealed with a rubber stopper to minimise the transfer of dust into the liquid.

Setting up the optical components:

First, adjust the mirrors M_1 [1,8] and M_2 [1,1.5] such that the laser beam runs parallel to the 2nd y co-ordinate on the base plate.

Position the beam splitter BS [1,2.5] with its magnetic base close to mirror M_2 . While doing so, ensure that the reflected partial beam also runs parallel to the 2nd y co-ordinate on the base plate. The metallized side of the beam splitter faces in the direction of M_1 . The beams, one of which emanates from the beam splitter and the other of which from the mirror M_2 , must always maintain the same separation along the travelling path! Check this with a measuring tape by holding it in the beam path at different distances from M_2 and BS . The separation should not be greater than 3 cm.

Now place the lens L_1 ($f = +100$ mm) at position [2,2] such that the two parallel beams strike the lens (symmetrically to the centre of the lens).

Adjusting the intersection point:

The two beams are made to cross by placing lens L_1 at a distance of 10 cm (at position [4,2]) behind the lens. For fine adjustment use the following arrangement:

Fix the pinhole diaphragm (diameter: $30 \mu\text{m}$) in an xy adjusting device that is, in turn, equipped with a stem and inserted into a magnetic base. The screen SC at position [11,2] (not displayed in Fig. 2!) serves as an observation screen. Now, set up the pinhole diaphragm at position [4,2] such that it is located in beam path height and exactly in the region of the intersection point of the two beams. Shift its position with the adjusting screws of the device in such a manner that the light spot (with diffraction phenomena) which previously emanated from the non-adjustable

Fig. 2. Experimental set-up for laser-Doppler anemometry

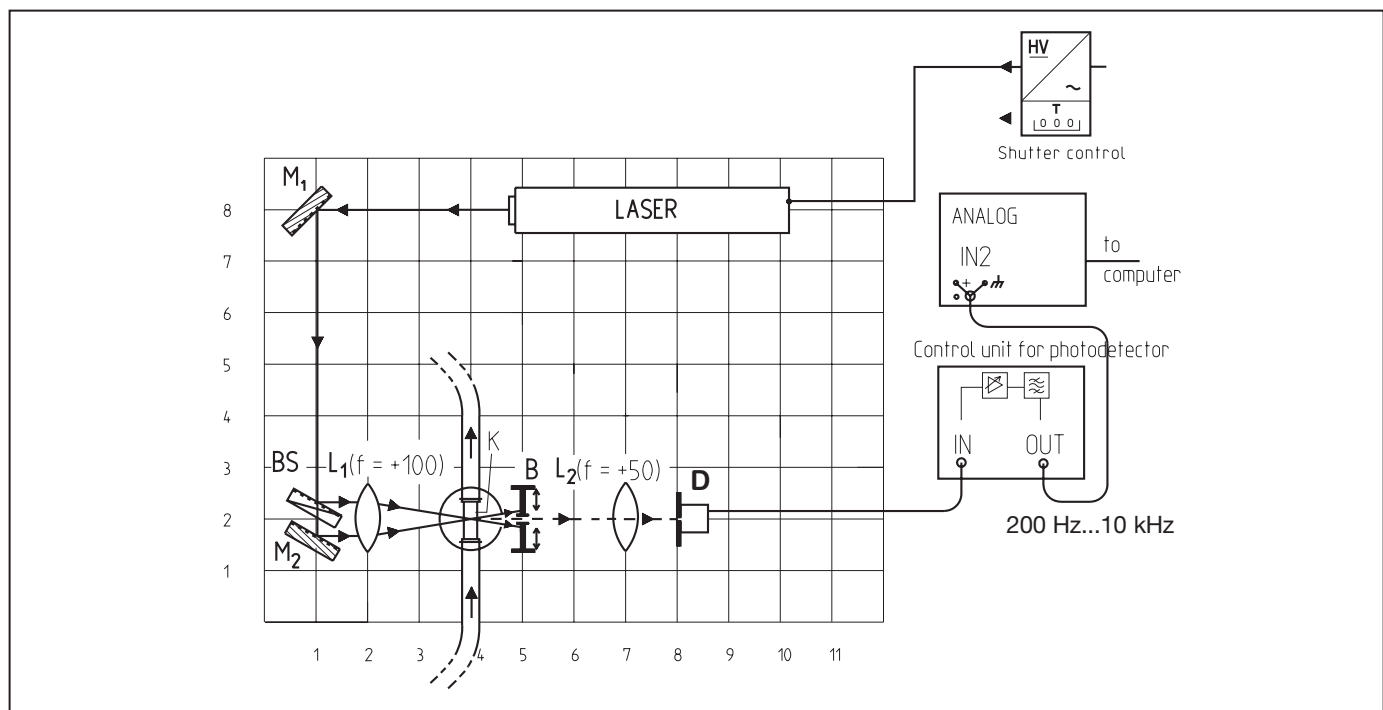

beam splitter **BS** appears on the screen **SC** to the right of the optical axis. Now, alter the second beam, which emanates from mirror **M₂** by finely adjusting mirror **M₂** such that this beam also passes through the pinhole diaphragm. A second luminous spot (with diffraction phenomena) appears on screen **SC**, which now is located to the left of the optical axis. Interference stripes can also be seen between the two light spots.

Qualitative examination of the interference region:

Whether an interference region exists at the intersection point of the two beams, can be qualitatively tested by reproducing this point with a second lens **L₂** ($f = +20$ mm). At a distance of 2 cm from the intersection point, set up **L₂** at position [4.5,2] (This cannot be seen in Fig. 1 or Fig. 2!). On a distant observation plane (wall at a distance of at least 4 m or screen **SC**, which has been turned on its axis perpendicular to the optical axis to expand the light point which is to be observed, Fig. 3), two lights spots appear. They can be made to coincide by readjusting mirror **M₂**. On closer examination of the illuminated area, one sees the interference fringes (example: at screen **SC** distance of 113 cm, the luminous spot has a diameter of 8 mm). Now, remove the optical components **L₂** and the screen **SC**.

Determination of the interference half-angle φ :

At a distance of approximately 2 to 3 meters, two luminous spots can be observed, which have made to cross by lens **L₁** at the focus, 10 cm behind the lens. Now, measure the distance l' between lens **L₁** and the observation plane and the distance of the two light spots D (see Fig.4). The distance of the intersection point to the observation plane l is determined by the difference $l' - f = l$.

Fig. 3. Schematic set-up for the reproduction of the interference region of the crossed laser beams

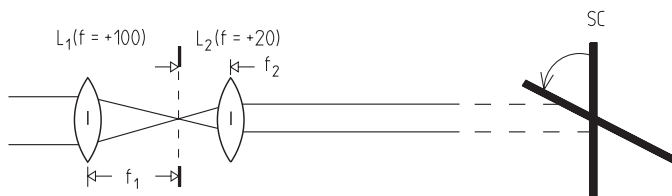
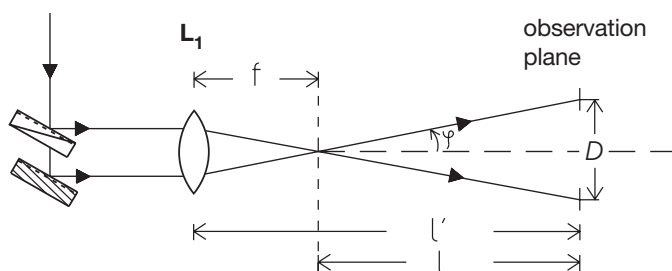

Fig. 4. Schematic presentation of the set-up for the determination of the overlap half-angle φ



Setting up the cell:

Pull the two O-rings each approximately 10 cm over the ends of the two pieces of silicone tubing, which have already been connected to the glass bottles with their other ends. Subsequently, cautiously press these ends of the silicone tubing with twisting movements onto the cell so that they extend approximately 1 cm onto the cell (see Fig. 5). Now, slip the O-rings onto the connection locations of the silicone tubing's ends and the cell to fix it.

Caution: The cell is made of quartz and very fragile. Therefore, handle it carefully! After connecting the cell to the two pieces of silicone tubing, clean the finger prints and traces of grease from the cell with a soft cloth!

Clamp the cell to the prism table with the fixing ball. The laser beam must strike the parallel cell walls perpendicularly! Now, place the prism holder with cell in the laser beam at position [4,2] such that the beams pass through the lateral surfaces of the cell and that the intersection point of the two beams is located in the middle of the cell (This can be best seen when the cell is filled with liquid!).

In the following, a flow of liquid through the cell should occur even when the hose clamps are just slightly opened. To achieve this, the filled glass bottle must be attached to the upper end of the support rod and the empty one, fixed at the lower position.

*Positioning the photo-detector **D**:*

Position an iris diaphragm **B**, whose aperture is reduced until the two main beams are not able to pass through it, in a lens holder behind the cell [5,2]. A lens **L₂** [7,2], with the focal length $f = +50$ mm, focuses the scattered light which emerges parallel from the cell onto the photo-detector **D** [8,2]. The signal from the photo-detector **D** is applied to a control unit, which amplifies and filters the signal.

This signal on the output of the control unit is applied to the input port IN2 on the Cobra3 interface (+ and GND).

Presettings of the measuring program:

Press the red <New measuring> -button, now the setting parameters, such as the scanning frequency, the trigger condition and the voltage range can be set.

Make the following settings:
the voltage range U/V is ± 10 V,
the frequency range f/kHz is 22.05

Fig. 5. Set-up diagram "glass cell"

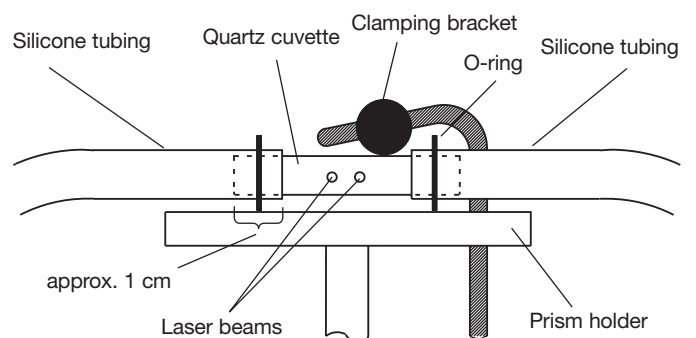

Continuously both, the signal and the spectrum are displayed, when the parameters are set according to Fig. 6. During aligning the set-up, it is recommended to select the “Measurement continuous” mode. During the fine adjustment don’t press neither the <Save> nor the <Close> buttons.

Now, the fine adjustment of the photo-detector **D** can be performed. Adjust it with its input opening positioned at the focus of the 2nd lens **L**₂ such that the time signal $F(t)$ exhibits its greatest voltage variations (upper diagramme).

Occasionally, so-called bursts, which show an undulation with a high frequency, should be visible. This is what you are locking for.

Shift the filled glass container to the upper position and the empty one to the lower position (see Fig. 1). To begin with, one hose clamp is kept tightly closed in order to subsequently be able to achieve low-velocity flow through the cell by opening it slightly. The flow can be observed due to the scattering of light in the cell (flashing of the scattering particles on flowing through the measured volume). In the process, the level of the liquid sinks only very slowly; thus, several minutes are available for the measurement.

On observing the spectrum $G(f)$ (lower diagramme), a measuring signal peak must now emerge from the background noise (see Fig. 7). The operating mode “Measurement continuously” off is recommended now. You can start a new measurement by clicking the “Measure” button! Repeat this until you get a “good” measurement signal, as you can see in Fig. 7.

At low flow velocities it is possible for the signal peak to move too far into the region of the direct current fraction on the spectrum ($f \sim 0$ Hz); in such cases it can only be localised with difficulties. Try different filter selections of the control unit for the photo detector.

At excessively high flow velocities turbulence may occur in the cell such that the result could be falsified by excessively great differences in the particle velocities. In addition, it is possible for a signal peak with higher frequency to be mirrored at the highest frequency location of the measured spectrum due to a property of the FFT algorithm, and thus still be visible. This case can be recognised by a shift of the signal peak to higher frequencies instead of lower ones when the current velocity slows (due to the unavoidable sinking of the liquid level). In this case select a higher sampling frequency!

When you have got a “good” signal, press the <Save> button. By means of the survey function (#), the mean frequency of the signal peak can be directly determined (display of the frequency below the signal display). See Fig. 8.

The velocity measurement (i.e., the determination of the mean frequency of the signal peak in the spectrum) is now performed at different flow velocities. To do this, the extent of the hose clamp’s loosening is varied: only very small changes in the degree of loosening (opening) are necessary! Take into consideration that after a change in the tightness of the hose clamp, one must wait approximately 2 min until the new diameter has established itself and the disturbances in the liquid flow have diminished.

Relevant information

The scattering bodies (glass beads coated with silver) sediment out after a few hours. Therefore, they should be returned to solution by shaking the liquid at regular intervals (every half hour)! The general background illumination should be kept as low as possible so that the signal peak in the spectrum is more easily seen.

Fig. 7. Measurement of the signal spectrum with a signal peak at 2344 Hz

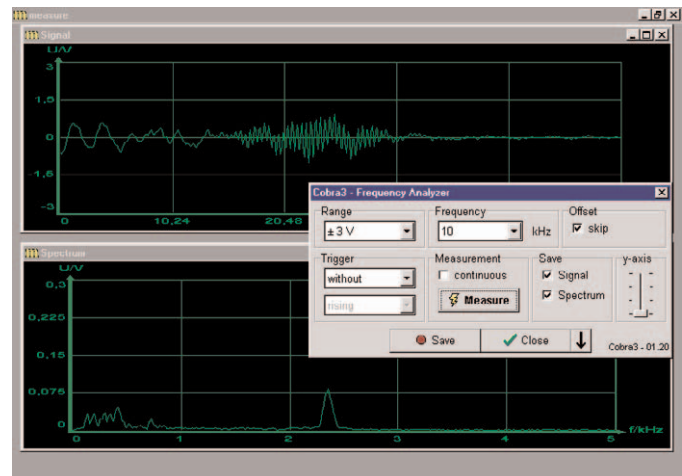

Fig. 6. Appearance of the program desktop. Display of the time signal $F(t)$ (upper curve) and the spectrum $G(f)$ (lower curve) of the photo-detectors voltage

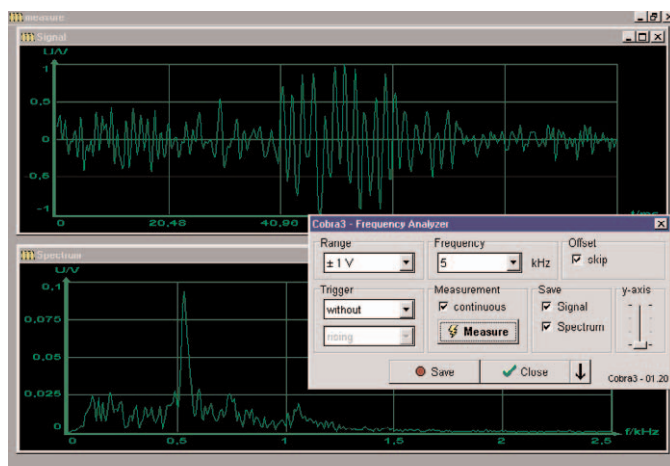
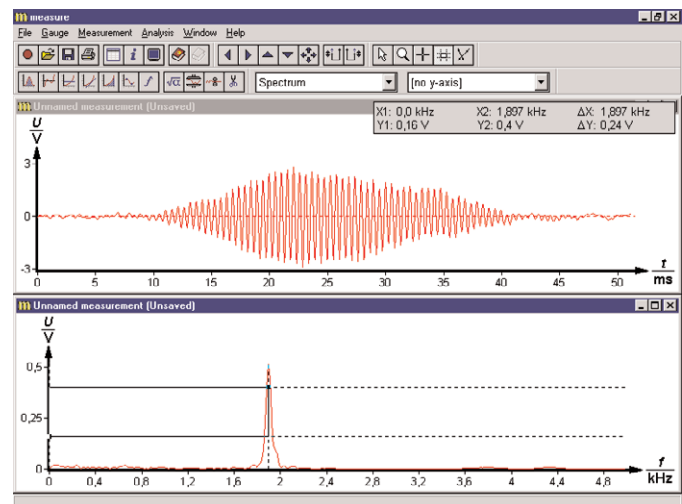

Fig. 8. Measurement of the signal spectrum with a signal peak



Theory and Evaluation

Doppler effect

Two cases of the Doppler effect are used to discuss the LDA principle (see Fig. 9).

- a) In the first case, a stationary light source and a moving receiver are present, where the velocity of the receiver is given by the vector \vec{U} . The light frequency at the receiver f_R is given in the following manner as a function of the transmission frequency f_s at the light source:

$$f_R = f_s \left(1 - \frac{\vec{U} \cdot \vec{l}}{c} \right) \quad (1)$$

where c is the speed of light in air.

- b) In the second case a moving light source is used and the receiver is stationary. Thus, the received light frequency is given as follows:

$$f_R = \frac{f_s}{\left(1 - \frac{\vec{U} \cdot \vec{k}}{c} \right)} \quad (2)$$

In LDA a laser is used as a stationary light source and small, flowing particles scatter the light, which is then received by a photodiode **D**.

The application of the two upper equations (1-2) provide the frequency of the light at the photocell after the laser light has been scattered by the moving particles and received by the stationary receiver (see Fig. 10):

$$f_R = f_s \left(1 - \frac{\vec{U} \cdot \vec{l}}{c} \right) / \left(1 - \frac{\vec{U} \cdot \vec{k}}{c} \right) \quad (3)$$

Twin beam anemometer

In the practical application, only a small Doppler shift of the light frequency due to the movement of the particles results, as follows from Equation (3), compared to the light's frequency. Thus, a direct measurement of the frequency (e.g. with the aid of a Fabry-Perot interferometer) can only be performed with insufficient accuracy.

There are different methods of avoiding a direct optical frequency measurement:

Due to the quadratic characteristic line of the photo-detector, it is possible to mix two light frequencies. Thus, the beat frequency of the two signals can be detected. For example, in the self-beating method, the frequency-shifted signal is mixed with itself (as measuring frequency, one obtains twice the difference frequency). Additional methods are the homodyne (one light source) and the heterodyne (two light sources) mixing.

In the arrangement presented here, the twin-beam configuration (two crossed beams from the same light source) is used (see Fig. 4).

In this arrangement, a laser beam is split into two partial beams having equal intensities, which are then focused in the measuring control volume (mcv) and made to intersect within this volume. Particles in the flow which passes through this overlap volume scatter the light of both partial beams. The Doppler shift of the scattered light is different for the two partial beams (different \vec{l} vectors, but the same \vec{k} vectors).

This difference, generally known as the beat frequency, is measured in the scattered light. This frequency difference is designated as the Doppler frequency and is substantially lower-frequency and has a more narrow band width as the source frequency of the light. Thus, an exact detection and measurement of this frequency with electronic means is possible. Now it will be shown that the Doppler frequency is proportional to the particle velocity.

The frequency of the scattered light for each of the two partial beams is given by the following:

$$f_{R1} = f_s \cdot \frac{\left(1 - \frac{\vec{U} \cdot \vec{l}_1}{c} \right)}{\left(1 - \frac{\vec{U} \cdot \vec{k}_1}{c} \right)} \quad (4)$$

$$f_{R2} = f_s \cdot \frac{\left(1 - \frac{\vec{U} \cdot \vec{l}_2}{c} \right)}{\left(1 - \frac{\vec{U} \cdot \vec{k}_2}{c} \right)} \quad (5)$$

The difference is given by:

$$f_D = f_{R1} - f_{R2} = f_s \cdot \frac{\vec{U} \cdot (\vec{l}_2 - \vec{l}_1)}{c} \quad (6)$$

Fig. 9. Two cases for the discussion of the Doppler effect

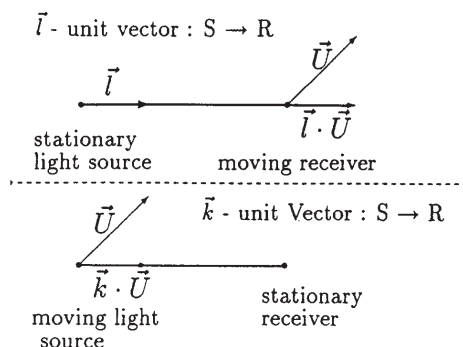
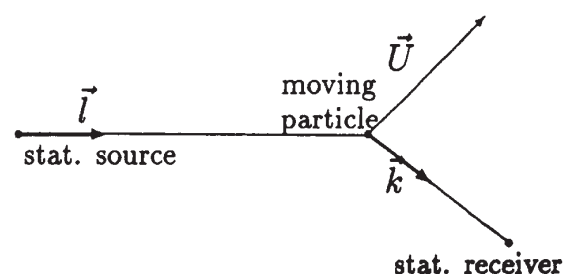

Fig.10: Scattered light of one moving particle



Using the relationships in Fig. 11 and the correlation $c = f_S \lambda$ (λ : wave length of the laser light), the Doppler frequency can be expressed as follows:

$$f_D = \frac{\vec{U} \cdot (\vec{l}_2 - \vec{l}_1)}{\lambda} = \frac{\vec{U} \cdot \vec{n} \cdot 2 \sin \varphi}{\lambda} = \frac{\vec{U}_\perp \cdot 2 \sin \varphi}{\lambda} \quad (7)$$

where \vec{U}_\perp is the velocity component of the particle perpendicular to the angle-bisection of the beam overlap region.

Equation (7) shows that the particle velocity can be measured by determining the Doppler frequency if a particle passes through the measuring volume (mcv). The beam overlap angle 2φ and the laser wavelength λ can also be determined with a high degree of accuracy.

The measuring principle of LDA can also be illustrated by the use of Moiré fringes (or also the grid model, Fig. 12). In this model the two laser beams intersect and form parallel interference fringes in the mcv. The moving particle then scatters alternately the constructive and destructive interference fringes in the measuring control volume (mcv), where the frequency of the intensity changes is directly proportional to the velocity components of the particle perpendicular to the grid. The separation of the fringes is designated as Δx and is given by Equation (8). The frequency of the intensity changes is thus given by

$$f_D = \vec{U}_\perp / \Delta x$$

(see Equation (7)).

$$\Delta x = \frac{\lambda}{2 \cdot \sin \varphi} \quad (8)$$

For experimental reasons, the interference fringes can only be considered qualitatively in this experiment.

Evaluation

In the course of the experiment, the overlap half-angle φ is determined. In doing so, the distance from the lens L_1 to the observation plane l' and separation of the two light spots on the observation plane D are measured (see Fig. 4). Thus, the angle φ is obtained as follows:

$$\tan \varphi = \frac{D}{2 \cdot l} \rightarrow \varphi = \arctan \left(\frac{D}{2 \cdot l} \right) \quad (9)$$

with $l = l' - f$ (f : focal length of lens L_1).

In a sample measurement, the following distances were determined:

$$D = 61.3 \text{ cm} \quad l' = 247.3 \text{ cm}$$

$$\text{with } f = 10 \text{ cm} \Rightarrow l = 237.3 \text{ cm}$$

This results in an overlap half-angle $\varphi = 7.36^\circ$.

Sample measurement:

In the measurement of flow velocities, the following frequencies (mean frequencies of the signal peaks) were measured for various flow velocities e.g.:

1. $f_D = 2750 \text{ Hz}$
2. $f_D = 9052 \text{ Hz}$

These can then be converted into flow velocities according to Equation (7), where the angle φ is given by Equation (9).

The following flow velocities perpendicular to the light's incidence U_\perp resulted from the measured frequencies f_D :

1. $U_\perp = 0.68 \text{ cm/s}$
2. $U_\perp = 2.23 \text{ cm/s}$

with $\lambda = 632.8 \text{ nm}$, the wavelength of the laser light.

Fig. 11. Differences in the unit vectors.

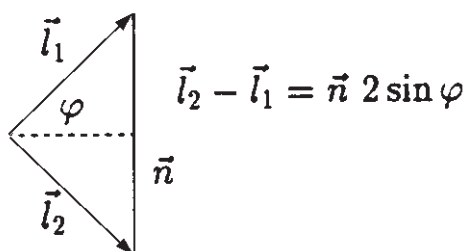

Fig. 12. Fringe model of LDA

